



# 2024 Big Fresno Fair Commercial Vendor Handbook

# COMMERCIAL VENDORS IMPORTANT DATES AND DEADLINES

AUGUST  
AUGUST 1

Deadline to receive Insurance Certificate

SEPTEMBER  
SEPTEMBER 1

All "NEW" additions or change requests due on product list

SEPTEMBER 1

Final Invoice Payment.

**NO PERSONAL CHECKS WILL BE ACCEPTED AFTER AUGUST 16<sup>th</sup>. CASH, MONEY ORDER, CASHIER CHECKS OR CREDIT CARDS ONLY. THERE IS A 4% FEE CHARGED ON ALL CREDIT CARD PAYMENTS.**

**WE NO LONGER ACCEPT AMERICAN EXPRESS.**

## Vendor Office Hours:

Pre-Fair 8:00 am – 4:30 pm

During Fair: 11:00 am – 7:00 pm

After 7:00 pm we will be on Grounds

## YOU MUST CHECK-IN BEFORE YOU UNLOAD OR SETUP

You must have a SLIP to give the supervisor of your building to start setting up, which you will receive after you check in. You will not be able to set up unless you have that SLIP.

**YOU MUST HAVE A TAG ON EVERY TRUCK AND TRAILER TO LEAVE IN LOTS. NOT HAVING A TAG WILL RESULT IN VEHICLE BEING TOWED AT OWNERS EXPENSE.**

## BUILDING SET UP PRE FAIR DATES

### SEPTEMBER

Saturday 28<sup>TH</sup>

Setup hours 9:00 A.M. - 6:00 P.M.

Sunday 29<sup>th</sup>

Setup hours 9:00 A.M. - 6:00 P.M.

Monday 30<sup>th</sup>

Setup hours 9:00 A.M. – 9:00 P.M.

### OCTOBER

Tuesday 1<sup>st</sup>

Setup hours 9:00 A.M. – 9:00 P.M.

**ALL BOOTHS MUST BE SET UP BY 9:00 P.M.**

## OTHER IMPORTANT DATES

### OCTOBER

Monday 7<sup>th</sup>

Seniors' Day & Special Interest Day-  
(NEW opening time 10:00am-10:00pm)

### OCTOBER

Wednesday 2<sup>nd</sup>

Dark Days- (NO HORSING RACING)

Thursday 3<sup>rd</sup>

Tuesday 8<sup>th</sup>

Wednesday 9<sup>th</sup>

Thursday 10<sup>th</sup>

### OCTOBER

Monday 14<sup>th</sup> LAST DAY

Outdoor Commercial-  
10:00 A.M. – 11:00 P.M. or Until Fair is  
cleared by PD

Monday 14<sup>th</sup> LAST DAY

Indoor Commercial-  
10:00 A.M. - 10:30 P.M.  
(or when fairgoers clear out)

### OCTOBER

Tuesday 15<sup>th</sup>

Buildings Open 10:00 A.M. – 3:00 P.M.  
**(Space must be vacated by 3:00 P.M.)**

# 2024 Commercial Hours

**NO VENDOR MAY OPEN LATE OR CLOSE EARLY**

**FAIR TIME HOURS: OPENING & CLOSING TIME FOR 2024**

## **EXHIBIT BUILDINGS HOURS:**

*Buildings open 1 hour prior to public opening except first day is 2 hours prior.*

<b>Day</b>	<b>Date</b>	<b>Opens</b>	<b>Closes to Public</b>	<b>Closes for Vendor</b>
Wednesday	Oct. 2	4:00 PM	10:00 PM	10:30 PM
Thursday	Oct. 3	10:00 AM	10:00 PM	10:30 PM
Friday	Oct. 4	10:00 AM	10:00 PM	10:30 PM
Saturday	Oct. 5	10:00 AM	10:00 PM	10:30 PM
Sunday	Oct. 6	10:00 AM	10:00 PM	10:30 PM
Monday (Senior Day)	Oct. 7	10:00 AM	10:00 PM	10:30 PM
Tuesday	Oct. 8	10:00 AM	10:00 PM	10:30 PM
Wednesday	Oct. 9	10:00 AM	10:00 PM	10:30 PM
Thursday	Oct. 10	4:00 PM	10:00 PM	10:30 PM
Friday	Oct. 11	10:00 AM	10:00 PM	10:30 PM
Saturday	Oct. 12	10:00 AM	10:00 PM	10:30 PM
Sunday	Oct. 13	10:00 AM	10:00 PM	10:30 PM
Monday	Oct. 14	10:00 AM	10:00 PM	10:30 PM

## **OUTDOOR COMMERCIAL BOOTHS**

<b>Day</b>	<b>Date</b>	<b>Opens</b>	<b>Closes</b>
Wednesday	Oct. 2	4:00 PM	11:00 PM
Thursday	Oct. 3	10:00 AM	11:00 PM
Friday	Oct. 4	10:00 AM	Midnight
Saturday	Oct. 5	10:00 AM	Midnight
Sunday	Oct. 6	10:00 AM	11:00 PM
Monday (Senior Day)	Oct. 7	10:00 AM	11:00 PM
Tuesday	Oct. 8	4:00 PM	11:00 PM
Wednesday	Oct. 9	10:00 AM	11:00 PM
Thursday	Oct. 10	10:00 AM	11:00 PM
Friday	Oct. 11	10:00 AM	Midnight
Saturday	Oct. 12	10:00 AM	Midnight
Sunday	Oct. 13	10:00 AM	11:00 PM
Monday	Oct. 14	10:00 AM	11:00 PM



## BALLOONS, STICKERS, DECORATIONS, AND FLASHING LIGHTS

Balloons and stickers cannot be given away under any circumstances. All balloons decorated inside and outside buildings MUST be pre-approved by Fair Management and helium tanks are not permitted in commercial buildings. The Big Fresno Fair will not be responsible for the loss or damage of any decoration material. No flashing lights, strobe, sirens, or any lights that cause a disturbance. All flying objects must have netting or be contained within your booth.

## BOOTH/STAND IDENTIFICATION

Each location MUST BE properly identified with the space name and number placed in a conspicuous location visible from in front of the booth/stand for the public to view. For this purpose, you may use official Fair space sign provided by the Fair.

## BOOTH/STAND LIMITATIONS

**Per California Fire Marshal there must be a 5 foot space in total on either side of fire extinguishers and fire hoses. All Outdoor Commercial Vendors must supply their own fire extinguisher in their booth.** Commercial booth displays including signs, should not be higher than 8'. Sidewalls should not exceed 8' beyond 4' from the back walls, however, anything above 8' high must be approved in writing by the Vendor office. Sidewalls beyond the 4' for the remaining 6' should not measure more than 3' high. Whenever possible, accurate measurements of space should be taken if the display is to be custom made for a particular location.

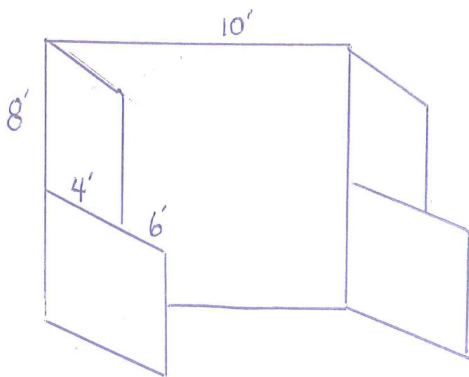

**Absolutely no personal electrical appliances (fridge, microwave, etc.) are permitted in any booth.**

All lighting strands must have a bulb, cover or a cap in each socket. ALL lighting must be LED lights.

Personal Canopies must be certified and labeled as fire safe. (Per CFSA and Fire Marshal).

## CANCELLATION REFUND REQUESTS

It is further understood and agreed that should a contractor fail, neglect, or refuse to pay their agreement fees at the time and in the manner they become due, or fail, neglect, or refuse to submit notification to the Association of cancellation of agreement by August 25<sup>th</sup>, neglect or refuse to open and/or conduct business in said agreed space and/or stand as agreed, Association will retain all monies paid herein as

liquidated damages. The parties agree that the above is considered a material breach and the Association may terminate said agreement and reassign said space to another party. It is further agreed that should an exhibitor notify Association of cancellation of their agreement by August 25<sup>th</sup> the Association will retain 50% of any monies deposited. **After August 25<sup>th</sup> there will be no refunds issued.** All cancellation refund requests must be submitted in writing explaining reason for cancellation. Request for refunds will be submitted for approval at the next regularly scheduled Board of Directors meeting.

## CANOPIES

If you require a canopy from the fair it must be ordered in advance for a fee. In order to secure a canopy for fair time use, prearrangement must be made with the Vendor office. Must be ordered in advance and paid in full by August 25<sup>th</sup>, 2023.

## CLOSING NIGHT INFORMATION

### DO NOT CLOSE EARLY

**Vendors in Buildings MUST remain open until 10:00 P.M., Sunday, October 14<sup>th</sup>.** Early closing will seriously affect your invitation to return in the future.

**On closing night NO vehicles will be allowed on the grounds until after 12 midnight or until management deems it safe.** There is no priority given to any vendor to park or come into the grounds. All vehicles must enter in through Gate 2. Staging will begin one hour after closing. Commercial Vendors will be escorted on grounds before Food Vendors. Cars are to begin lining up going east bound on Lyell from Cedar. Upon closing to the public, teardown can begin using hand carts. No security is provided after 1:00 A.M. on closing night. Any product left will be at vendor/owner risk. The Big Fresno Fair assumes no responsibility for theft/loss of products. Release forms will be delivered closing night about 9 p.m. Area Representatives will be stationed around the grounds to make your entrance and exit go as smoothly as possible.

Buildings will close to vendors at 2:00 A.M. sharp on closing night. Buildings will be open from 9:00 A.M. to 3:00 P.M. on Tuesday October 15<sup>th</sup>.

Everything should be removed from the Fairgrounds by 3:00 P.M., Tuesday, October 15, 2024, unless prior permission is obtained through the Vendor Office. Storage fees may be charged on any item left after 3:00 P.M., October 15, 2024. If fairgrounds personnel must remove any exhibit from an area a fee of \$30.00 per man hour plus \$35.00 per hour for equipment use will be charged. Any shipments/stock left to picked

up will be at the risk of the vendor/owner. The Big Fresno Fair takes no responsibility for damage/loss.

## COPIES

Copies can be made in the Vendor office for a fee. Each copy will be 15¢ for black and white 8.5x11 single sided and 70¢ color 8.5x11 single sided.

## DAILY CLOSING PROCEDURES

You must remain open during scheduled building hours. You may not leave booth until Area Supervisor gives the ok to leave building. If you leave early or before given the ok the Big Fresno Fair is not responsible for any lost, stolen, or damaged merchandise and/or equipment.

**IF ANY EXHIBITOR SHALL FAIL OR REFUSE TO ABIDE BY THESE RULES, THE BIG FRESNO FAIR RESERVES THE RIGHT TO TERMINATE THE CONTRACT AND TO TAKE POSSESSION OF ANY MONEY PAID BY THE EXHIBITOR TO THE BIG FRESNO FAIR.**

## DAMAGES

You agree to promptly reimburse and pay the Big Fresno Fair for any damages to Fair property or equipment that you, your employees, or your agents cause during the term of the Rental Agreement/Contract by October 14<sup>th</sup> of contract year.

## DEMONSTRATIONS

Demonstrations are limited and subject to the approval and regulations of the Vendor office. Demonstration area must be organized within the exhibitor's space so as not to interfere with any traffic aisle, and sampling or demonstration tables must be placed a minimum of 2' BACK from aisle line. Should spectators or samplers interfere with the normal traffic flow in the aisle or overflow into neighboring exhibits, Fair Management will have no alternative but to request that the presentation or sampling be eliminated. These are limited and subject to approval and regulation of the Fair Management.

## DRAWINGS

Vendors who desire to hold drawings or have prize promotions must have the written approval of the Fair Vendor office. Letter must have detail explanation of drawing. Drawings and lead gathering information forms may only ask for name, address, e-mail, and phone number.

Signage must indicate type of program patrons are registering for (i.e. timeshare, membership, real estate development, etc.) and state: **“Winners need not be present to win” and “No purchase necessary to participate”.**



Free drawings must be held at the booth/space during fair hours in front of public audience. Winner's name, address and phone number must be submitted to the Fair Vendor office by 10:00 PM closing night of the Fair or by 10:00 PM the day of each drawing if multiple drawings are conducted. Holding your drawing after this deadline makes it invalid and may affect your ability to hold drawings at future Big Fresno Fair's. You and you only, must conduct all drawings. Any information obtained from the drawing entry form is to be used strictly by you and it's not to be sold or given to another company or individual except for the Big Fresno Fair. You also agree that there will be no games, gambling, or any other activity on the premises in which money is used as a prize or premium nor can you buy back discount coupons for cash.

Raffles are not allowed under any circumstances. Only free drawings that comply with all applicable federal, state, and local statues and ordinances will be permitted. Failure to abide by any of the above guidelines will jeopardize any use of drawings in future fairs.

NO SPINNERS/WHEELS OF FORTUNE, ETC. ARE PERMITTED WITHOUT APPROVAL.

### **DRUG-FREE WORKPLACE**

In a commitment to safeguard the health of our employees and to provide a safe environment for everyone, **we have a DRUG-FREE WORKPLACE policy** that extends to all of our vendors. Our policy now formally states that substance abuse will not be tolerated on the fairgrounds, including parking lots. This prohibition includes the possession, use or sale of illegal drugs or being under the influence of alcohol. Any person in possession or under the influence of alcohol or illegal drugs will be immediately removed from the fairgrounds. It is important to work together to deal with substance abuse to make this a safe and rewarding place to work.

### **EARLY TRAILER DROP OFF OR LATE PICK UP**

Anyone needing to drop off a trailer before September 28th, 2023 should call the office to make arrangements. If needing to leave stand or equipment after October 20, 2023 call the Vendor office to make arrangements. Trailer storage is charged @ \$35.00 per night.

## ELECTRICAL AND PLUMBING

All electrical and plumbing changes must be approved by the Vendor Office.

Electrical surcharge for commercial: see order form for pricing.

Electrical installations will conform to the Electrical Safety Code of the State of California. The use of over length extension cords will not be permitted inside of any building or outside stands. **All cords must be 3 wire grounded** and of appropriate size for load and U.L. approved. **Do not** connect extension cord to extension cord; provide the proper amount of extension for the space needed.

Overhead lighting adequate for ordinary purposes is provided. There is one 120V, 60 cycle A.C. 120 duplex outlet in each booth (maximum electrical load per 10' booth: 1000 watts). Any special requirements must be made in advance and approved by the Vendor office. Additional wiring is to be arranged and installed at vendor's expense by Fairgrounds maintenance staff.

NOTE: Electric appliances such as coffee pots, space heaters, air conditioners, hot plates, refrigerators, and microwaves which are intended for the personal convenience of vendors and their staff **ARE NOT PERMITTED**.

**All trailers, lighting, and displays must be LED. All string lights must have bulbs/caps in each socket.**

## EXCLUSIVITIES & METHOD OF SELECTION

Please note The Big Fresno Fair does not grant exclusivity for products, services or exhibits except in a sponsorship situation. As fair time approaches and as booth spaces become limited, vendors with similar or same products may, by necessity, be placed in close proximity. If you are found to be selling products not on your contract, you will be asked to remove these items immediately. You will also be issued a written violation. Issuance of 3 violations will result in closure/removal of your booth.

## FAIR PROPERTY

All signboards, signs, sign letters, electrical fixtures, and plumbing fixtures (except those furnished by the contractor) are the property of the Big Fresno Fair and are not to be removed. Any such items missing during the 12 days of the Fair will be charged to the contractor occupying the space.

## FINES

Any fines that the fair receives as a result of a vendor will be passed on to the vendor.

## FIRE REGULATIONS

The State Fire Marshal requires the following Rules and Regulations be brought to the attention of all contractors. Also find enclosed, Code Enforcement pamphlet. These rules are in accordance with State Fire Laws:

### FLAME PROOFING

**All Decorative Material, Table Cloths, etc. must be flame proofed** to meet the requirements of the State Fire Marshal. All flame proofing **must be done prior to installation** in any building or fairgrounds premises. **All tents and canvas covering must have the label saying Flame Proofed** or be flame proofed in accordance with fire regulations. A certificate of flame proofing **WILL** be required to be inspected by the State Fire Marshal. For information on flame proofing you may contact any fire extinguisher company.

### COMBUSTIBLE TRASH

**All combustible trash must be removed daily.** There will be no combustible trash storage allowed behind any of the displays (inside or outside of the buildings).

### FLAMMABLE LIQUIDS

All demonstrations or display stands using flammable liquids must have approval by the State Fire Marshal.

### LIQUID PETROLEUM GASES

**No person shall install or maintain an L.P. gas container without a permit.** Any Propane Tank that is 12 years and older will not be filled unless they have been recertified and have the correct up to date accessories to be filled with. **L.P Gas containers are not allowed inside the buildings.**

### **AISLE & EXIT WAYS**

All aisles and exits are to be kept clear of all storage, etc. at all times.

### **EXIT DOORS**

All exit doors shall be operable from the inside without any special effort or knowledge. All locks and chains shall be removed.

### **FIRE HOSES & EXTINGUISHERS**

All fire hoses and extinguishers shall be accessible and unobstructed at all times. You must work around the Fire Hoses and Extinguishers in your booths and make sure they can be seen in all directions.

### **FIRE HAZARD**

All automobiles on display shall have the gas tanks sealed and battery disconnected.

### **CYLINDER STORAGE**

All compressed gas cylinders shall be secured against tipping.

**All outdoor commercial vendors must have a fire extinguisher in their booths.**

### **FIRST AID**

Professional medical personnel are on the grounds during all operating hours of the Fair. Please direct any persons needing medical assistance to our First Aid Office, which is located on the South Side of the Livin' Local Marketplace Building (Formerly Gem and Minerals)

### **FORKLIFTS**

Any person operating or driving a forklift on fair property MUST be a CFSA certified operator. Failure to do so could result in a non-return invitation. **If forklift is needed closing night, prior arrangements must be made with vendor office prior to closing night.**

## GOLF CART RULES

THE USE OF GOLF CARTS ON THE FAIRGROUNDS HAS BECOME A SERIOUS CONCERN OF FAIR MANAGEMENT. IF THE FOLLOWING RULES ARE NOT SERIOUSLY ADHERED TO, THE PRIVILEGE OF USE MAY BE REVOKED TO ALL.

- Golf Cart fee is \$100.00 to be paid in full by September 1.
- You must have Golf Cart coverage on your insurance. Insurance Certificate must be provided when Golf Cart permit is issued.
- In order to operate a cart (electric or gas powered) on the fairgrounds, you must have an official BIG FRESNO FAIR permit sticker obtained at the Vendor office.
- You must have prior approval from the Vendor office in order to operate a cart. Insurance coverage must be included on your liability insurance policy. Credentials will be enclosed in packet.
- ONLY LICENSED DRIVERS may operate carts on the Fairgrounds.
- No open alcoholic beverage containers are allowed on carts, and no cart driver shall be under the influence of alcohol.
- Cart drivers must use perimeter roads whenever possible.
- Cart usage must be limited to business purposes only. NO JOYRIDING.
- Carts should be kept at a reasonable speed at all times. If, in the opinion of the Fair you are caught speeding or driving recklessly, the Fair's decision in the matter will be final. If any cart or use of cart, in the opinion of the Fair is deemed unsafe, the permit for said cart will be revoked.
- Carts operated on the Fairgrounds must have a key for operation and must not have the key left in the ignition.
- Carts MUST NEVER be parked in pedestrian traffic areas.
- All golf carts are to yield to pedestrians and vehicles at all times.
- Cart drivers MUST avoid heavily congested areas.
- DO NOT LEAVE YOUR CART IN DOORWAYS.
- You must schedule your deliveries with carts prior to 3:00 P.M.
- In order to relieve congestion on the Fairgrounds all golf carts must be parked by 5:30 P.M or earlier when warranted.
- Legs, feet, and arms must be kept inside the cart at all times during operation.
- California Motor Vehicle Laws apply to all operation of golf carts.
- Every passenger on the golf cart must have a seat as described by the manufacturer.
- All riders must have credentials to enter the fair
- Bicycles also require permits, and fall under the same rules and regulations as carts. Bicycle permits are free of charge and may be obtained from the Vendor office.

FAILURE TO COMPLY WITH THE RULES WILL RESULT IN CANCELLATION OF THE PERMIT AND THE CART WILL BE IMPOUNDED BY THE FAIR FOR THE DURATION. SHOULD CART PERMIT BE CANCELED, THE FEE WILL NOT BE REFUNDED.

## GUEST SERVICES

Guest Services and our Found Child Center, the “Gingerbread House”, is located West of the Commerce Building and to the North of the Chance Entrance. Anyone seeking information, assistance, wishing to make suggestions, complaints or find a lost child should be directed to the Guest Services/Found Child Center.

## ICE

The Fair has contracted with Arctic Ice Company for ice during the Fair. The price per bag will be determined before fair. If you need assistance arranging ice delivery, please contact:  
32 Below Ice: Chris Drake 559-375-4232

## INFORMATION BOOTHS

Information Booths provide directions, answer questions and offer general assistance to all Fairgoers. We have four booths located on our grounds which are open from the time gates open until 10:00 p.m. each day. The four locations are at the Chance Entrance, The Butler Entrance, in front of the Brian I. Tatarian Grandstand and at the north end of the Sports Zone. A water is available to patrons in all booths.

## INSURANCE

**The Big Fresno Fair and the State of California requires all contractors to have a liability policy that shall be provided and maintained throughout their occupancy at the Fairgrounds.**

**YOU MAY PURCHASE INSURANCE THROUGH THE FAIR’S VENDOR OFFICE.**

**COMMERCIAL VENDOR \$ 165.00**

**The State of California requires proof of Workers’ Compensation Insurance coverage for all commercial vendors who are not an independent contractor and have paid or volunteer employees. A certificate of Workers Compensation Coverage must be provided.**

**Certificates of Insurance MUST specify coverage for both electric or gas powered golf carts, powered electric carts, and cycles for those of you who have those vehicles, or listed with CFSA. If name on insurance is different from name on Fair’s contract, make sure you have both names on certificate.**

**VERY IMPORTANT. Insurance is due to Fair by August 1<sup>st</sup>**  
**\*NEW THIS YEAR\* - All Vendors will be charged for our Insurance if we have not received a copy of their insurance by the deadline.**

**\*New Contracts received after August 1<sup>st</sup> will have 7 days to provide proof of insurance.**

## The Following **MUST** be on your insurance:

### List as Additional Insured:

“THAT THE STATE OF CALIFORNIA, THE DISTRICT AGRICULTURAL ASSOCIATION, COUNTY FAIR, THE COUNTY IN WHICH THE COUNTY FAIR IS LOCATED, LESSOR/SUBLESSOR IF FAIR SITE IS LEASED/SUBLEASED, CITRUS FRUIT FAIR, CALIFORNIA EXPOSITION AND STATE FAIR, OR ENTITIES (PUBLIC OR NON-PROFIT) OPERATING CALIFORNIA DESIGNATED AGRICULTURAL FAIRS, THEIR DIRECTORS, OFFICERS, AGENTS, SERVANTS, AND EMPLOYEES ARE MADE ADDITIONAL INSURED, BUT ONLY INSOFAR AS THE OPERATIONS UNDER THIS CONTRACT ARE CONCERNED.”

- 30 DAY CANCELLATION
- CERTIFICATE HOLDER

FRESNO FAIR  
1121 S. CHANCE AVE.  
FRESNO, CA 93702  
Vendors@



## INTERNET

If you require INTERNET SERVICE, please contact Comcast at 1-800-391-3000. In some areas where wires must be flown, the Fair may deny service due to aesthetic or safety purposes.

## KNIVES & SHARP OBJECTS

**There will BE NO FREE KNIVES GIVEN AWAY FOR ANY PURPOSE. If you are selling Knives or Dangerous Items, said items must be displayed in a case.**

If you sell knives or other similar items you **MUST** have a plan for fair goers to pick-up their objects prior to departure from the fair, eliminating them from having sharp objects while on the Fairgrounds. The plan **MUST** be approved by Fair Management in order to sell such item.

## LICENSING

If you sell a product it will be your responsibility to obtain the necessary permits that are required by the city, county, or state. Management reserves the right to determine whether an item is considered offensive or in poor taste, and to prohibit the sale/display of such an item. No selling of confederate products is permitted.

## LOAD IN/SET UP PROCESS

**Outdoor booths may be erected any time from Wednesday, September 25<sup>th</sup> through Tuesday October 1. Indoor booths begin Saturday, September 28<sup>th</sup>.** Vehicles that are unloading during the time they are setting up must display a “Vehicle ID Permit” visible on the dashboard, or they will be towed away. Any vehicle parked blocking or interfering with the flow of traffic will be towed. After you have unloaded, you must proceed to find parking off of the fairgrounds. You will be responsible for any fines if you are towed. Keep aisles clear from trash and boxes.

No guard service will be provided before 9:00 A.M. on Saturday, September 28<sup>th</sup> and then we cannot guarantee security of booth. All boxes, crates and debris must be removed prior to opening day of the Fair. Everyone must breakdown cardboard boxes.

## LOST AND FOUND

Items lost during fair can be taken to Fair Administration, Guest Services, Info Booths or the Police Office on the fairgrounds located in the front of the grandstands.

LOST ITEMS AFTER THE FAIR CALL POLICE OFFICER JANETTE OLSON:  
559-621-2342

## LOST PARENTS

ID Wristbands are FREE to every child and patron who walks in as a guest of the Big Fresno Fair. ID Wristbands are to help provide your information to police and guest services in case of a separation from group or party. Patrons are responsible to put their phone number clearly on the ID wristband.

## MAINTENANCE REQUESTS

If you require maintenance assistance for hookups, plumbing or electrical, please come to the Vendor office to fill out a Maintenance Request Form. **If there is an emergency or power outage, contact us by phone at (559) 650-3213.**

## MEDIA PROTOCOL

The Media on grounds at The Big Fresno Fair are critical to the Fair's overall success. As such, please respect our media and their time. Do not approach the media regarding your product/business directly. Our public relations team works diligently to feature a wide variety of exhibitors and vendors at The Big Fresno Fair. If you have a product that you would like the media to be aware of please contact our public relations team directly. Should media approach you for an interview, please be sure a member of the public relations team is there. Public Relations Team Contact Information: Danielle Griffin, Communications Director 559-994-3133 or [danielle@cohencommunications.com](mailto:danielle@cohencommunications.com).

## MUSIC, SOUND DEVICES & FLASHING LIGHTS

Radios, television sets, loud speakers, amplification systems, musical instruments, etc., are subject to the approval of the Vendor office and must be controlled so as not to interfere with other contractors. The use of amplification systems is a privilege. All music will be monitored by Fair Management. You will get 1 (ONE) warning, next warning and you will be banned from playing music in your booth/stand. (DON'T ABUSE).



All speakers must be in the rear of the booth or stand pointing down towards the ground and volume must remain at the level designated by the Fair. If interferences exists or persists, the Fair reserves the right to revoke your privilege of using any sound devices at any time. No flashing lights, strobe, sirens, or any lights that cause a disturbance.

## **NOVELTIES AND GIVEAWAYS**

Commercial Vendors will not be allowed to sell or giveaway the following novelty items in their booths: Balloons, photo buttons, plush animals, badges, canes, whistles, peanuts, beach balls, small plastic toys, inflatable toys, stickers, gum, patches, knives, switch blades, brass knuckles, high power water guns, rubber band toys, products made from endangered animals, pornographic or drug related items, or anything else that could be construed as a weapon. Management reserves the right to determine whether an item is considered offensive or in poor taste, and to prohibit the sale/display of such an item. Watches and sunglasses must be listed separately. Violations will be considered grounds for cancellation of contract and all money paid will be forfeited to the Big Fresno Fair. Any product declared by the Fair, in its sole discretion to be a novelty item will not be permitted to be displayed, promoted, sold or given away from any exhibit space.

## **OVERNIGHT PARKING/DEAD STORAGE/SHOWERS**

There are no facilities for overnight parking. Overnight parking is not allowed in the paid parking lots (Butler/Infield/Chance Parking Lots) of the Fair. Large trailers and vehicles (dead storage only) can be parked in the Chili's Parking Lot located at the northeast corner of Maple and Butler Street; you must obtain a parking pass from the Vendor office.

There is NO sleeping in personal vehicles in any parking lot, including the RV parking; anyone caught sleeping in vehicles other than their RV will be subject to fine and removal from the premises. There are NO showers available on grounds. If anyone is caught showering inside the fair they will be subject to losing their vendor space and removal from the premises.

## **PARKING AND GATE INFORMATION**

All parking permits are to be obtained through the Order Form. Any other permits needed after the fair is open must go to the vendor office. Parking on grounds is prohibited during regular fair time hours. ALL vehicles must be removed by 9 a.m. Friday thru Monday and 3 p.m. Tuesday thru Thursday or will be subject to being towed at the owner's expense along with a fine from the Fair. All vehicles entering the grounds must have a pass and enter through Gate #2, which is located south of the

Administration Building on Chance Ave. You must have a pass with company name, phone number, space number in a visible location on your dashboard.

**Parking for Commercial Vendors will be in the employee parking lot**, which is located on the South East corner of Butler and Maple and is free. You will be issued parking permits for this lot. Please try to have employees drive together and not have one for each employee. You will receive two permits with each 10x10. If you do NOT need this number of parking passes, please indicate on the order form.

A shuttle will take you to and from the Fairgrounds. Hours begin at 6:00 a.m. every day; last shuttle during the week is 11:30 p.m. and weekends 12:30 a.m.

Friends of the Fair parking: is available in the lot located at the Northwest Corner of **Chance and Lane for \$ TBD** and can be purchased in advance on your order form. **(LIMITED to 1 per Booth)**

## **PERSONNEL - SERVICE**

**It is of the utmost importance that our rapport with our guests be a positive experience for all.**

**ABSOLUTELY NO SUBLEASING OF BOOTHS IS PERMITTED. DOING SO WILL RESULT IN A \$1,000.00 FINE AND YOU WILL NOT BE ASKED TO RETURN IN THE FUTURE.**

- YOUR BOOTH/STAND MUST BE STAFFED AT ALL TIMES DURING OPEN HOURS. AN UNOCCUPIED BOOTH HAS VERY LITTLE VALUE TO YOU OR TO YOUR PATRONS.
- The Fair has the right to limit the number of staff in your booth.
- Any unoccupied booth will be written up.
- Insist on smart appearance and no loafing.
- Emphasize courtesy and avoid all offensive situations.
- Elaborate literature should be kept under the counter and given only to obviously interested customers.
- Contractor is responsible for all claims, liabilities and actions relating to the conduct and representations of personnel in said space.
- Contractor hiring anyone under the age of 18 years MUST have a work permit issued by school authorities. Permit must be available in booth for inspection by the proper authorities.
- All employees must have a way to contact the owner for problems and any concerns.
- Emphasize NO Smoking, NO Alcohol or Sleeping in booth.
- In an effort to maintain professionalism children and pets of staff should not be in booth.

- If you have any problems during the Fair please contact either the building supervisor or the Vendor office immediately to have your issues addressed.
- No animals other than service animals should be on grounds at any time.

## PETS

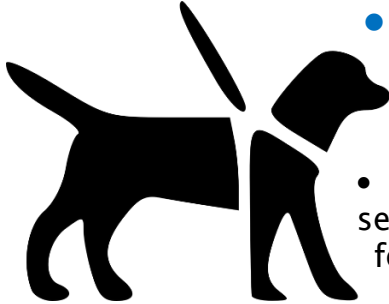

- **Sorry pets are not allowed**
  - **Service animals are trained working animals, not pets. \***

- State and Federal law prohibits all animals, except for service animals, in grocery stores, restaurants, and other food establishments where food is being served, sampled, and sold, such as fairs.
- The Americans with Disabilities Act (ADA) authorizes the use of service animals in a food establishment ONLY for the benefit of the individuals with disabilities. A service animal is a dog that is individually trained to do work or perform tasks for people with disabilities. If you have a question regarding the use of a service animal in this fair, please speak with a member of management. \*Dogs and pets whose function is to provide comfort or emotional support DO NOT qualify as service animals according to the ADA.

## PITCH SALES

If you are using a microphone at your booth to pitch your products, you **must** purchase a **Pitch Sales Permit** from the Vendor Office for \$500.00. Permit must be displayed at your booth at all times. All speakers must be in the rear of the booth or stand pointing down towards the ground and volume must remain at the level designated by the Fair. If interferences exists or persists, the Fair reserves the right to revoke your privilege of using any sound devices at any time.

## PROPANE

Propane is available to purchase during the fair. Price will be determined and given prior to opening day of fair. You are responsible for taking your tanks to the maintenance department to be filled. On closing day propane is only available until 3:00 p.m. If you have old tanks, you may not be able to fill them.

## RECEIPTS

Sales slips, with contracted business name, address and telephone number must be furnished with each item sold to a patron. This is for the licensee's protection as well as that of management. Failure to do so will result in violation that can affect future participation.

## RECYCLING

The Big Fresno Fair has embarked on an aggressive recycling program in an effort to address environmental concerns. We are committed to doing our part to insure a clean, environmentally safe world for future generations to enjoy and we need your cooperation!

All Vendors are required to breakdown (flatten) All cardboard boxes and place them beside the designated trash dumpsters behind the buildings or beside your stands for easy pick up each day.

**Use of polystyrene (Styrofoam) is prohibited for all vendors and concessionaires. (There is a biodegradable recyclable polystyrene available at most wholesale & retail stores.)**

**Polystyrene (Styrofoam) packing/shipping materials will need to be removed from the grounds by the vendors. It will not be allowed to be disposed of on grounds.** Polystyrene foam or Styrofoam packaging products are an environmental hazard when they escape into the ground. Please do your best to request the use of biodegradable or water-soluble packaging material from your manufacturers.

**We ask that you steer away from handing out plastic bags and use recycled content paper bags for your customers.**

***ANY VENDORS FOUND TO NOT BE ADHERING TO THE MANDATORY RECYCLING POLICY WILL BE PUT ON WRITTEN NOTICE FOR THE FIRST VIOLATION AND YOUR BOOTH SPACE FOR 2023 MAY BE IN JEOPARDY. FINES WILL BE IMPOSED IF NECESSARY. LET'S ALL WORK TOGETHER!***

## REGULATION FOR CONDUCT AND ACTIVITIES

The Big Fresno Fair recognizes that a Fair is a proper forum for the free exchange of ideas necessary to a free society, yet reserves the right to regulate all activities, concessions and exhibitions on the Fairgrounds with regard to time, manner and place in pursuance of its valid interest in maintaining peace and order and protection of the general public. Contractor shall comply with all applicable State and Federal laws and be familiar with the procedures and information set forth in the rental agreement.

The Fair reserves the right to prohibit a concession or exhibit or any part which in the sole judgment of the fair detracts from the character of the concession or exhibit or which may be objectionable or offensive to neighboring contractors or the public. This restriction extends without limitation to persons, things, conduct, signage or printed matter. Per Government Code section 8195: The state of California may not sell or display the Battle Flag of the Confederacy or any similar image.

## RV/STOCK TRUCK

RV spaces are extremely limited. An RV Camp Host will be on grounds throughout the Fair. The Camp Host can be contacted through any RV gate attendant. Any issues that arise regarding the campgrounds will be addressed by the Camp Host.

Stock trucks with sleeping quarters in them will be placed on the opposite side of the fence in the Butler parking lot and allowed to plug into one 110 outlet (if available) for electricity only, for a fee of \$125.00. Water and sewer will not be available. If you would like to be placed inside the RV lot with full hookups, you will be required to pay the full RV price of \$525.00.

Vendors will be responsible for your animals business and any kind of trash left in your RV space. Please check out with RV attendant to confirm your space is clean. If you leave anything behind you will be charged a cleanup fee of \$250.00.

**RV VISITORS/GUESTS** In an effort to keep RV lot secure during the fair any vendor requesting a guest into the RV lot must ask permission prior. RV owner will need to provide names of guest to Camp Host. Guests must check in to sign in and out with the RV Camp Host. They will need to provide who they are visiting and will be provided a temporary RV lot badge. Any issues or problems that occur will be the responsibility of the RV owner.

## SENIORS' DAY

Seniors' Day is October 7, 2024. ALL outside vendors must be open and ready to operate by 10:00 a.m. There are no exceptions. All vehicles must be off grounds by 8:00 a.m.

## SHIPPING AND RECEIVING

Shipping and Receiving is open Monday thru Saturday 9:00a.m. until 3:00 p.m. Generally United Parcel Service and Federal Express deliveries arrive between 9:00 A.M. and 11:00 A.M. The deliveries are dropped off behind the Commerce Building (Westside). The responsibility ultimately rests with you for knowing you are expecting deliveries. You may check with the shipping and receiving office staff to verify if attempts have been made by the delivery companies. To expedite our attempts of notification, please notify your senders to include your exhibit booth number (i.e.; C-201). The name on the address label should be the same as that on your contract. All packages are your responsibility to be picked up; Fair will NOT be delivering small packages or mail. If a large order will be delivered please make prior arrangements with fair staff if assistance is needed with a golf cart or forklift. If you will need a forklift to move your product around during fair time, it will be a fee of \$50.00 per occurrence.

If any product is coming before the fair, make sure it is properly addressed and leave notice in the Vendor office. Any deliveries that are being sent and incomplete could be sent back to sender. All products that you are requesting to be shipped from the Fresno Fair after closing day must be picked up by 12:00 P.M. October 16, 2023.

### **PLEASE NOTE PROCEDURE CONCERNING C.O.D. DELIVERIES**

You may leave checks or Money Orders with the supervisor in the shipping office located at the rear of the Commerce Building, prior to parcel arrival. **WE WILL NOT ACCEPT CASH.**

### **SIGNS**

All signs, banners, or posters must be professionally made, neat in appearance and placement must meet the Big Fresno Fair guidelines. No hand written signs will be allowed.

### **SMOKING POLICY**

The Big Fresno Fair is a **SMOKE FREE FAIR**. There will be no smoking on the grounds except in designated smoking areas. Positively NO smoking will be allowed in booths. Violation notices will be given if anyone is caught smoking in booths. There is NO smoking allowed within 20 feet of any building doors.

### **DESIGNATED SMOKING AREAS**

The following are designated smoking areas (subject to change)

- WINE GARDEN
- SPORTS ZONE
- CANTINA
- AREA SOUTH OF PAUL PAUL THEATER
- GRANDSTAND (Except for areas established for non-smoking)
- \*VENDORS\* BEHIND COMMERCIAL BUILDINGS (Designated by Building Supervisor)



**NO SMOKING HERE**

### **SOLICITATIONS - HANDING OUT MATERIALS**

The sale or distribution of any merchandise, products promotional items and printed or written materials except from a contracted and fixed location on the Fairgrounds is not permitted and SHALL NOT be handed to any fair patron unless so requested.

### **SPONSORSHIPS AND THIRD PARTIES**

Contractor may not enter into any sponsorship/promotional partnership(s) or marketing initiative(s) where a sponsor/third party receives advertising or promotional consideration without obtaining, annual written approval from Fair Management. Contractor must submit a plan six (6) months prior to each annual Fair in writing, for review by Fair Management.

## STAKES

Absolutely no stakes are allowed to be placed into the ground asphalt, dirt, grass, cement or brick without prior approval of management. Anyone who does so will be responsible for any damages and repair.

## STATEMENTS

Statements for special electrical service, installation charges and other services will be presented to contractors and are due and payable before the close of the Fair.

## THEFT

Security is on grounds 24 hours a day in all areas. However, it is impossible for them to be everywhere all the time. Plan to lock up or remove any valuable items which may be carried by hand. Also, small items should be placed to the rear of the booth or under counters each night. On closing night, security will not be provided after 1:00 A.M.

**IF THEFT OCCURS, PLEASE CONTACT THE FAIR OFFICE IMMEDIATELY, SO A REPORT MAY BE FILED AND SECURITY AND THE POLICE ARE NOTIFIED.**

## TIP CUPS/JARS

No Jars, Cups, Decorative Items to give the incentive of customers leaving a tip is allowed.

## TRASH

Please do not throw or sweep trash into the aisles. Trash containers are provided for this purpose in or near all areas and buildings. Breakdown boxes and stack them outside neatly at or near back door of commercial buildings. Those demonstrations that require food and vegetables must provide their own clearly marked, leak-free garbage cans. These must be large enough to handle a full day's operation. All cans must be emptied each night for early morning pick up. Fair personnel will not remove trash or clean inside booths.

## VIOLATIONS

Any violations concerning cash or sales by either the commercial owner or his employees may result in immediate expulsion from the fair and will have a serious bearing on your invitation to return as a concessionaire in the future.

**A violation includes, but is not limited to, non-compliance with any of the following:**

- Personnel – neatly attired, well groomed, following hand washing and food handling requirements, courteous and responsive
- No smoking and/or drinking of alcohol in or around the stand/booth
- Customer service and consideration of neighbors
- **Ringling of each sale at the displayed price and closing cash drawer after each transaction**
- General appearance of stand must be attractive and clean
- Business conducted within the assigned space, keeping the area around the stand dry, clean and unobstructed.
- Cleanliness of condiment area and seating area (if applicable)
- All signage professionally done and prominently displayed
- Items sold as listed on Rental Agreement (menu)
- No price changes after September 1<sup>st</sup>
- Cooperation with neighboring stands, noise level reasonable
- Smoking in undesignated areas.
- Use of foul/unprofessional language towards Vendors, Patrons, and/or Fair Staff.

**If you are found to be in violation of any of the above rules and regulations, the following will occur:**

**1<sup>st</sup> violation** - Verbal warning. Will also be written simply stating that the matter had been discussed with you, date, time, etc.

**2<sup>nd</sup> violation** – If the matter has not been tended to in a timely manner (usually 24 hours, depending on the violation) you will receive a written citation.

**3<sup>rd</sup> violation** – No invitation to return will be granted or could result in escorting you and your stand off the property

**Any violation having to do with money not being properly handled or reported is grounds for immediate removal from the grounds.**

## **WORKING CREDENTIALS**

Working credentials ticket book will sell for (\$4 x13 days) \$52.00 each. Vendor badge will sell for \$40.00 each. Working credentials will be in books of 13 tickets. Each ticket is good for any day of the fair. Vendors may purchase a maximum of **4 ticket books credentials** per 10' x 10' space and **2 ticket book credentials** for each additional 10' x 10' space at these prices. Individual tickets can be bought for \$8.00 each. Working credentials are not for “be back customers”, friends, relatives, etc. **They are for working staff only.** Misuse or resale of these tickets is strictly prohibited and doing so will be cause for cancellation of your contract. Your cooperation with this will help us keep costs down for the fair and all



vendors. If a Vendor badge is purchased and lost, a new Vendor badge must be issued for an additional \$35.00.

**The Photo ID RV badges are required for all vendors and staff staying in the RV parking lots. Additional Photo ID RV Badges will be \$35.00 each and Badges will be checked upon entry into RV lot. \*NO EXCEPTIONS\*.** RV photo ID badge is good for entry into the fair at all public entrances. Entry into Vendor gate behind Commerce Building is badge entry only. All Vendors may be subject to search/wanding by security personnel. All Vendors using tickets for entry must use public entrances. WFA badges are acceptable as entry admission to fair only, not RV lot.

**CREDENTIALS WILL NOT BE GIVEN OUT WITHOUT ALL FEES BEING PAID IN THE VENDOR OFFICE.**