

# FIVE FLAGS CENTER

## Technical Information



**Five Flags Arena**



**Five Flags Theater**



**Mailing & Shipping Address:**

Dubuque Five Flags Center

405 Main St.

Dubuque, IA 52001

(563) 589-4254

Booking Contact: Aaron Rainey, General Manager - [Arainey@fiveflagscenter.com](mailto:Arainey@fiveflagscenter.com)

**Center Personnel:**

General Manager:	Aaron Rainey	<a href="mailto:Arainey@fiveflagscenter.com">Arainey@fiveflagscenter.com</a>
Director of Finance:	Greg Olson	<a href="mailto:Golson@fiveflagscenter.com">Golson@fiveflagscenter.com</a>
Director of Events & Operations	Jesse Cosens	<a href="mailto:Jcosens@fiveflagscenter.com">Jcosens@fiveflagscenter.com</a>
Event Manager:	Nick Farfan	<a href="mailto:Nickfarfan@fiveflagscenter.com">Nickfarfan@fiveflagscenter.com</a>
Technical Production Manager:	Zack Giese	<a href="mailto:Zgiese@fiveflagscenter.com">Zgiese@fiveflagscenter.com</a>
Box Office Manager:	Alyson Tasker	<a href="mailto:Atasker@fiveflagscenter.com">Atasker@fiveflagscenter.com</a>
Marketing Manager:	Ty Bailey	<a href="mailto:Tbailey@fiveflagscenter.com">Tbailey@fiveflagscenter.com</a>

**Telephone & Internet:**

Main Office 563-589-4254

Box Office 563-589-4258

Fax 563-589-4351

**Ticket information:** Ticketmaster

**Market Information:**

Population: City – 60,000

County – 100,000

90 Mile Radius – 2.54 million

Two Big Ten Universities located within 90 miles. Immediate area is home to six colleges with total enrollment of nearly 19,000.

Located at conjunction of four major federal highways, making for easy travel from any direction. Situated along Mississippi River, creating a significant tourism sector.

Median age: 38 years old

Median income: \$54,000

28% of homes have children.

92% of population has graduated high school.

89% of homes have a computer.

Venue located in downtown business and nightlife district. 33 restaurants, 33 bars, and five hotels are within a 10-minute walk of Five Flags Center.

**Misc Info:**

Easy in and easy out with quick rigging.

5,200 seat full service arena, with an attached theater building with seating capacity of 711.

Total stage width on West End and East End stage, 60' by 40' with 12' wide by 24' deep sound wings, not to exceed 84'.

Total stage width on a North Side stage, 60' by 40' with 12' wide by 24' deep sound wings, not to exceed 84'. If a larger stage is needed, seats will have to be cut from the floor seating sections.

Seating charts available upon request.

**Location of Five Flags Center:** Five Flags Center makes up an entire city block, bordered by 4th, 5th, Main, and Locust Streets.

**Driving Directions to Five Flags Center:**

*From East or West:* On US Highway 20 (known locally as Dodge Street), arrive at intersection with Locust Street just to the west of Julien Dubuque Bridge. Turn north on Locust Street and drive 0.4 miles to Five Flags Center.

*From North (Iowa):* Iowa Highway 3 enters Dubuque on the city's far north side, and is locally marked as Central Avenue. Continue on Iowa 3/Central Avenue to 5<sup>th</sup> Street. Turn right (west) and travel two blocks to Five Flags Center.

*From North (Wisconsin):* US Highways 61/151 bring traffic across the Iowa-Wisconsin Bridge into Dubuque. Take exit for "9<sup>th</sup>/11<sup>th</sup> Streets." From exit ramp, turn right (west) onto 11<sup>th</sup> Street. Travel five blocks to Central Avenue. Turn left (south) and travel six blocks to 5<sup>th</sup> Street. Turn right (west) and travel two blocks to Five Flags Center.

*From South:* US Highways 61/151 enter Dubuque in the suburb of Key West. Continue on US 61/151 into downtown Dubuque. Take exit for "White Street/Port of Dubuque." From exit ramp, take first left (west) turn onto 4<sup>th</sup> Street. Travel three blocks to Five Flags Center.

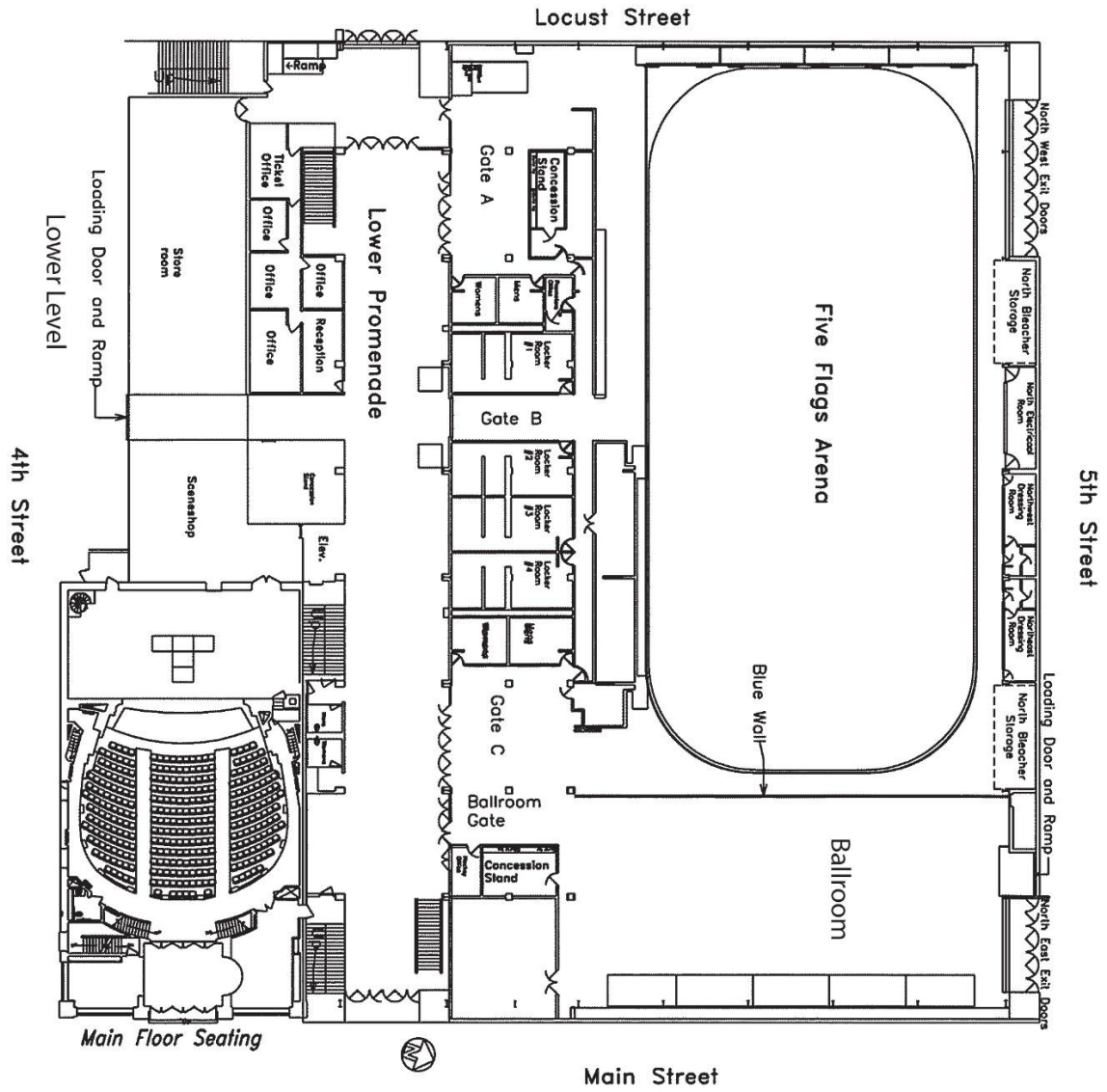

## **General Arena Information:**

Capacity: 5,200 (4,600 with typical production holds)  
Floor Size: 238' x 92'  
Square Footage: 24,512  
In-house curtaining, lighting system for cut-downs and theater type shows in the arena  
Union House

### **Load-in Information:**

Parking: 5th Street, North side of building. For larger events, street will be shut down and secured  
Loading Door: 20'h x 10'w (on 5th St)  
Stage Door: 6'h x 2'-8" w (on 5th St)  
No Dock: Load at street level

### **Stage Information:**

Manufacturer: StageRight  
Module size: 4' wide by 8' long  
Number Available: 102 decks and 36 frames: 60 ft. X 40 ft. *Please note: Max width of stage is 84 ft. in the room.*  
Stage Height Range: 4ft. to 6ft.  
Barricade: Yes, 120 feet blow through Manufacturer: StageRight  
Step Units: 3  
Hand Rails: StageRight Stage.  
Stage Skirt: Yes, black in color.  
Blow through barricade: 120feet

### **Electrical Power:**

#### **Amps Phase Distance from Upstage Center**

600	3/0	Cam-Lock (ground/neutral reversed)	Can be delivered any place in Arena
200	3/0	Cam-Lock (ground/neutral reversed)	Can be delivered any place in Arena
200	3/0	Cam-Lock (ground/neutral reversed)	Can be delivered any place in Arena
400	3/0	Tails only	

With cam-locks connection, neutral and ground reversed on the 600 and 200 amp disconnects.

Power Drops: single 20 amp U-Ground connector or double duplex outlet per box, single phase are located throughout the Arena on our overhead catwalks and can be placed almost anywhere in the Arena.

**Curtains:** Approximately 600 linear feet of varying black velour curtains 26' high that can be used to modify room for various cut-down layouts.

### **Dressing Rooms:**

<b><u>#</u></b>	<b><u>Size</u></b>	<b><u>Distance from Stage</u></b>	<b><u>Restroom/Shower</u></b>	
1	16 x 16	Depends on stage placement	Yes/Yes	Locker Room
2	14 x 16	Depends on stage placement	Yes/Yes	Locker Room
3	14 x 16	Depends on stage placement	Yes/Yes	Locker Room

4	14 x 16	Depends on stage placement	Yes/Yes	Locker Room
5	8 x 21	Depends on stage placement	Yes/Yes	Chorus Room
6	8 x 21	Depends on stage placement	Yes/Yes	Chorus Room

**Lighting and Sound:**

Intercom: Clear-Com. Hardwired throughout the arena. 9 single muff headsets, 14 double muff headset, 18 belt pack

Lighting Fixtures: Some in-house lighting is available, but only by prior arrangement.

PAR 64: 32 all medium lamps

Par 64 on Double Hung Truss: 120k, Lamps: Medium

Sound: Some in-house sound is available, but only by prior arrangement.

House Lighting: The house lights are controlled from the arena light booth. Two types of house lighting are available: Dimmable house lighting with incandescent fixtures and metal halide fixtures (Non-dimmable).

**Rigging:**

Rigging: Easy

Open Style Truss, Truss Height 7ft.

Height: 35' to bottom of truss, to top truss 42'

NOTE: All rigging off of Top of Truss

Beam weight limit: 6,000 lbs./beam. With a few beams at a limit of 2,000 lbs.

Beam structure: Open truss

Building top: Gradual rise

Manlift: Yes

Catwalk: Yes

Spread of beams/Beam length: Building width

Width between beams: 7'

Advance: If needed

Remarks: Easy building to rig - lots of open steel with some obstructions. *Must rig from top steel.*

**Other Information:**

Runner: Ask for additional information in advance

Piano: Available for rent by prior arrangement. The pianos are tuned on an as needed basis. Make: Yamaha Grand Piano Size: 7ft. Make: Yamaha Upright Size: 4ft. Make: Wurlitzer Spinet Size: 3ft. *Any tuning will be billed to the requesting user group.*

Piano Tuner: Brian Marceau Cost: \$150.00 per tune

Hospital: Mercy Hospital (563) 589-8000 8 blocks away

Finley Hospital (563) 582-1882 12 blocks away

Oxygen: Finley-Hartig Home Care (563) 588-8707

Pyrotechnics allowed: **Yes**

Permits required: **Yes** and Fire Marshall will be notified

Fire Marshall: Kevin Esser (563) 589-4161

Plants: Call for recent vendor list

Hotels: Holiday Inn Dubuque/Galena (563) 556-2000 (connected to Arena)

Hotel Julien Dubuque (563) 556-4200 (2 blocks from center)

Curfews: None

Airports:

Dubuque Regional – DBQ (7 Miles away)	563-589-4127	American Eagle
Eastern Iowa – CID (63 Miles away)	319-362-8336	All Carriers
Quad Cities Intl– MLI (80 Miles away )	309-764-9621	All Carriers

**Equipment available for rent:**

Follow spot Lights: Super Trouper Xenon Number: 4, Throw distance: 75' to 205' (depending on spotlight and stage location)

Bike Rack: 244 total running feet

Pipe and Drape: Enough hardware, drapes, and side poles and drapes to complete 150, (10x10) booths

Forklift: Komatsu. Lift Capacity: Weight: 6,000 lbs. Height: 12'-10"

**Catering:** All catering is in house. Please contact F&B Manager

**Stagehands:** Stagehands are IATSE Union members.

Technical Manager	\$35.00
Stagehands	\$30.00 - 4 hr. minimum
Loaders	\$30.00 - 4 hr. minimum
Forklift Operator	\$35.00 - 4 hr. minimum
Riggers	\$47.00 - 4 hr. minimum
Electrician	\$31.00 – 4 hr. minimum
Performance:	
Deckmen	\$30.00 - 4 hr. minimum
Follow-spot Operators	\$31.00 - 4 hr. minimum
Camera Operators	\$31.00 - 4 hr. minimum
Wardrobe	\$31.00 - 4 hr. minimum
Hair/Make-up	\$35.00 - 4 hr. minimum

**Misc Info:**

Easy in and easy out with quick rigging.

5,200 seat full service arena, with an attached theater building with seating of 711.

Total stage width on West End and East End stage, 60' by 40' with 12' wide by 24' deep sound wings, not to exceed 84'.

Total stage width on a North Side stage, 60' by 40' with 12' wide by 24' deep sound wings, not to exceed 84'. If a larger stage is needed, seats will have to be cut from the floor seating sections.

Seating charts available upon request.

**Arena Full Reserved East Stage**  
Five Flags Center, Capacity: 4,022 Seats

Potential Revenue  
**\$0.00**

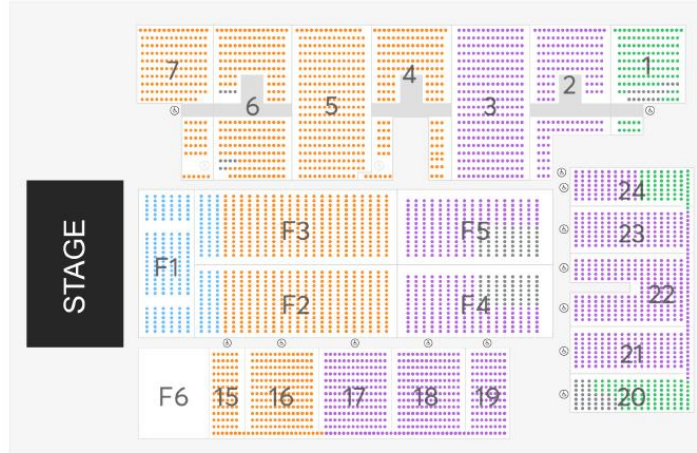

Price Level	Base Price	Total Capacity	Kills	Sellable Capacity	Total
● Price Level 1	\$0.00	240	0	240	\$0.00
● Price Level 2	\$0.00	1,679	0	1,679	\$0.00
● Price Level 3	\$0.00	1,834	0	1,834	\$0.00
● Price Level 4	\$0.00	269	0	269	\$0.00
<b>Total</b>	<b>Avg / seat: \$0.00</b>	<b>4,200</b>	<b>178</b>	<b>4,022</b>	<b>\$0.00</b>
● Unassigned Seats	-	178	-	-	-

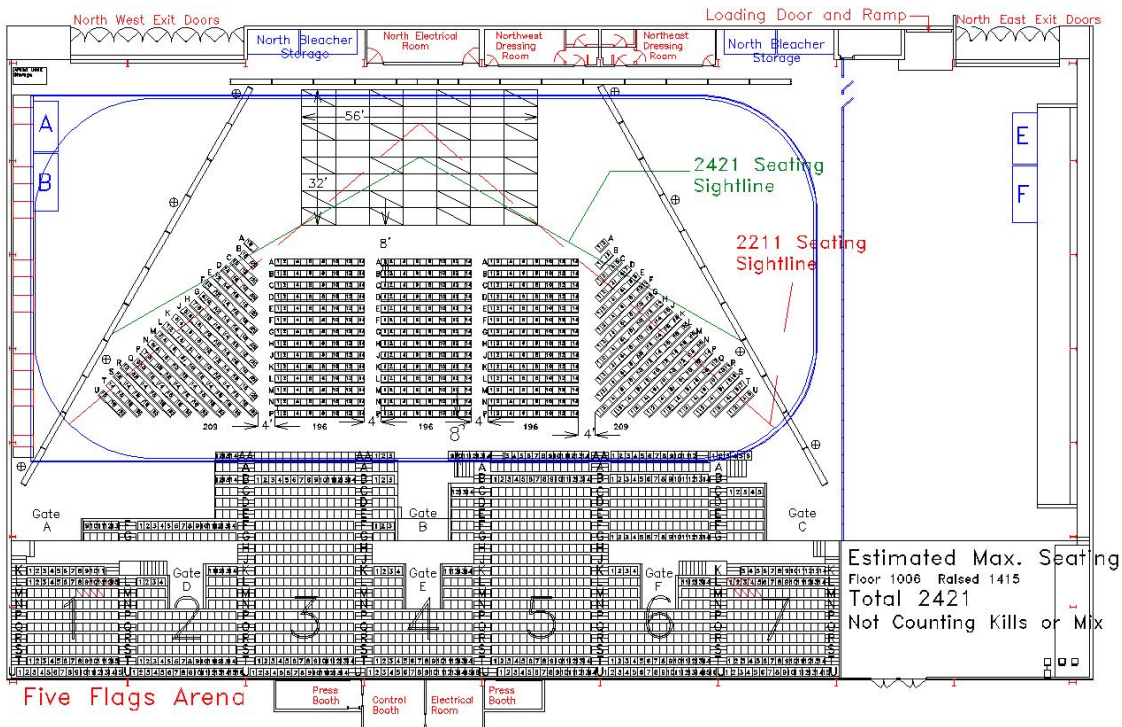

Estimated Max. Seating  
Floor 1006 Raised 1415  
Total 2421  
Not Counting Kills or Mix

Five Flags Arena



Five Flags Overhead Trussing/Steel  
 Rated at 6000 pounds per Truss

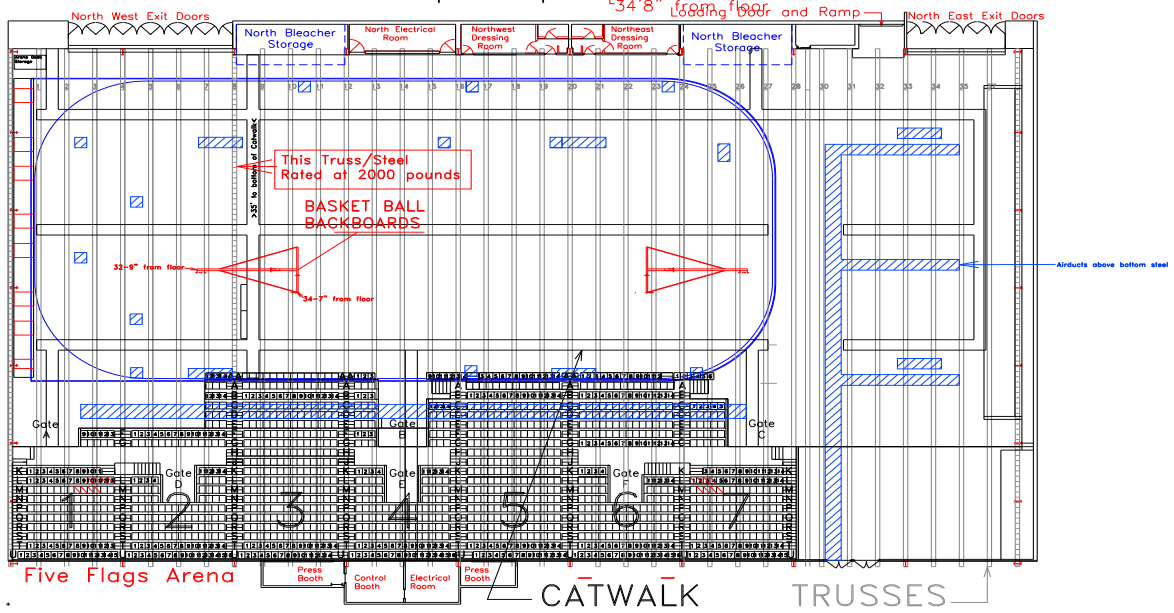

View from east end stage:

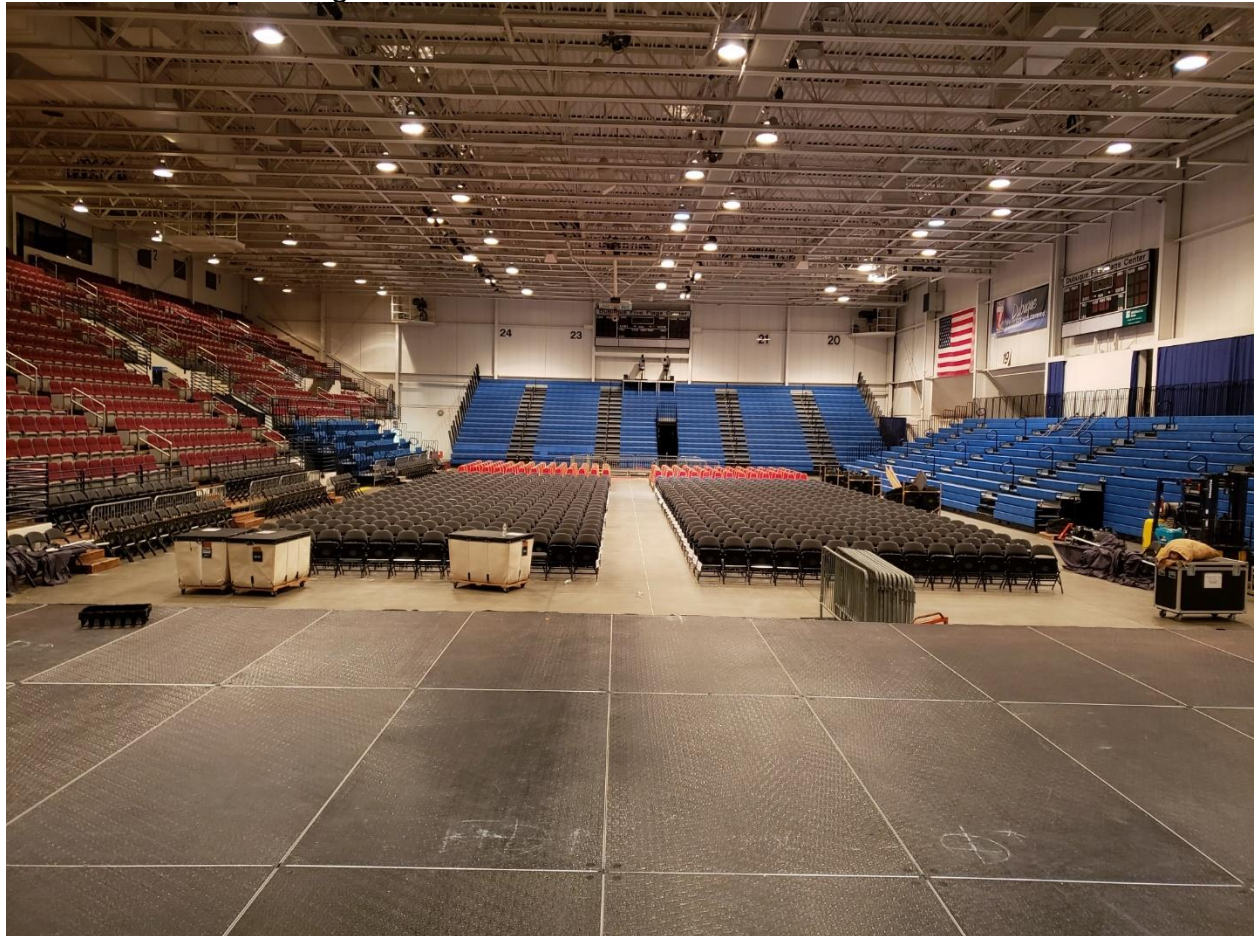

Fifth Street Loading Dock:



## **General Theater Information**

### **Seating Capacity:**

Main Floor (Orchestra Level)	322
Mezzanine	38
Balcony	<u>351</u>
Total	<u>711</u>

### **Loading Doors:**

Stage Door	6'-10"h x 3'-1/4"w
Scene Shop to Stage	15'-8"h x 3'-11"w
Scene Shop to Stage	7'-6"h x 6'-1/2"w
Store Rm. to Shop	20'-0"h x 10'-0"w
Street to Store Rm.	20'-0"h x 12'-0"w

Loading information and travel distances:

When entering the theatre from 4th St, you access the building through the 4th St. overhead door – distance from the street to the door is approximately 20 feet; then, through the Store Room to the Scene Shop overhead door approximately 10 feet; then, through the Scene Shop the Theatre stage overhead door approximately 30 feet; then onto the stage.

*NOTE: Both the Stage Door and the Loading Door are located on 4th Street.*

*Stage Floor:* Soft wood suspended floor with dull black-brown finish. Any user group must check with facility management before driving any fastener into the stage floor.

*Traps:* The traps are located in the center of the stage.

### **Orchestra Pit & Equipment:**

Size - The Pit is fan shaped in eleven sections. Approximate overall size: 32 feet wide, 11 feet deep, 6.5 feet below the stage.

Pianos - A piano is provided by prior arrangement. The pianos are tuned on an as needed basis.

Make: Yamaha Grand Piano Size: 7ft. Condition: Good

Make: Yamaha Upright Size: 4ft. Condition: Good

Make: Wurlitzer Spinet Size: 3ft. Condition: Fair

*Note: Any tuning will be billed to the requesting user group.*

Music Stands: 15 Manhasset stands and 17 lights are available.

Pit Positions: Stage Floor level, Audience level and Pit Floor level.

*NOTE: There is a labor charge for setting and striking the Pit Sections. The pit normal position is audience level.*

### **Orchestra Shells:**

Three sections of overhead acoustical baffles are available; they are stored in a vertical position.

Orchestra shells in stored on line sets #4, #13, #23

### **Fly System:**

A manual single purchase counterweight system of 33 line sets is located on stage right. A spotline (hemp line) system is also in use and is operated stage right at the pin & rail level above the stage floor.

**Curtains Available:**

1	Border	42'-0"w x 10'-0"h	no pleat
4	Border	42'-0"w x 8'-0"h	no pleat
8	Legs	8'-0"w x 24'-0"h	no pleat
1	Curtain	34'-8"w x 23'-10"h	no pleat
1	Movie Screen	27'-0"w x 20'-0"h	
1	Cyclorama	45'-0"w x 28'-0"h	
1	Plum Main Curtain	36'-0"w x 28'-0"h	50% fullness Guillotine style (split in center, may be paged)
1	Plum Valence	36'-0"w x 6'-0"h	50% fullness

*Note: The above curtains are velour or similar in appearance*

**Scrims:**

White	36'-0"w x 28'h
Black	30'-0"w x 25'h
Black	42'w x 24'h

**Control Information:**

House lighting controls and Stage Manager's desk are located on stage right on the down stage wall, at the plaster line. Dressing and storage room paging system is at this location. Stage Sound and Lights are controlled from a booth in the balcony with clear visibility to the stage.

**Dressing Rooms:**

Three chorus type dressing rooms seating 9 each and one Star dressing room is located below the stage, accessed from the spiral stairway USR. Paging communication between Stage Manager and dressing rooms is provided.

**Movie Screen:** A 27-foot by 20-foot front projection screen is permanently hung on counterweight pipe #10.

**Cyclorama:** A white Leno Sharks-tooth cyclorama is provided.

**Shop Space:** Located directly behind the back wall of the stage. It has access to the stage by double doors and an over-head door.

**Electrics:**

Company Switch (up stage right) 200 amps 3/0 5 wire  
Light control board: ETC Express 250 Control System, 192-2.4Kw dimmers

**Circuit Locations and Distances:**

2nd Balcony throw 65' 36 circuits

Center Box Mezzanine	throw 49'-9½"	No Circuits
Box Booms (2)	throw 28'-0"	9 cir/side
1st Electric	(2'-5" upstage of plaster line)	22 circuits
2nd Electric	(9'-3" upstage of plaster line)	18 circuits
3rd Electric	(15'-4" upstage of plaster line)	18 circuits
4th Electric	(22'-2" upstage of plaster line)	20 circuits
2 Plug-in strips above floor (SL & SR)		6 cir/side
Fly Galleries 18' up above stage floor		2 cir/side
Drop Boxes (8) 4 circuits per box		32 circuits
Plug in box up stage left		<u>12 circuits</u>
Total Circuits		192 circuits

**Available Lighting Fixtures:**

4	6x22 ellipsoidal	Altman	575w
4	6x16 ellipsoidal	Altman	575w
49	6x12 ellipsoidal	Altman	575w
60	6x9 ellipsoidal	Altman	575w
8	Source 4 19°	ETC	575w
8	Source 4 26°	ETC	575w
30	Source 4 10°	ETC	575w
60	6 inch Fresnel	Altman	500w
4	four color cyc lights	L&E Runt	650w per/strip/color

**Sound and Communication:**

Sound control board: Allen Heath GL2000 24 input, 4 output.

Amplifiers: Crown K2 dual channel, main system; Crown D-75A dual channel, monitor system

Equalization: Klark Tech 300 graphic equalizer, for each channel of the main system

Ashley MXQ 1310 graphic equalizer, for two channels of the main system

**Speakers:** Two fixed EAW AS660e speaker cabinets  
Two semi-portable RCF HDM-45A self powered speakers  
Two Electro-Voice TL Series: FM 12-2  
14-piece RCF HDL -10A line array  
4 RCF SUB8003-AS II  
4 RCF ST12-SMA II  
2 RCF ST15-SMA II  
2 RCF HDM45

**Microphones:** 3 AKG D-90-S  
12 Audix OM5  
6 Shure ULX wireless systems.

Including, D2/SM58 handheld, D1 Bodypacks, WL 185 Lavalier mics, SM35 headset mics

Microphone Stands: 8 black straight round base, 6 black tri-pod, 2 silver tri-pod, 15 boom arm.

Communication: Clear Com system with stations throughout the theatre is available by prior arrangement.

**Stage Dimensions:**

Between Fly Floors	46' - 6"	
Centerline Left to Prop Dock	23' - 5"	
Centerline Right to Pin Rail	23' - 1"	
Proscenium	Width	31' - 10"
	Height	26' - 8"
2nd Balcony	Throw	65'
Center Box Mezzanine	Throw	49'-9½"
Wall-to-Wall	60' - 3"	(55' - 7" clear)
Plaster Line to Back Wall	28' - 4"	(27' - 4" clear)
Plaster Line to Down stage edge of Pit	11' - 0"	
Front of Apron to Back Wall	31' - 4"	(w/ pit down)
Front of Orchestra Pit to Back Wall	39' - 4"	(w/ pit up)
Clear Wing Space	Stage R clear	7' - 0"
Clear Wing Space	Stage L clear	7' - 0"
Additional wing Space	Stage R	3' - 0" (off) x 19'-0" (high)
Additional wing Space	Stage L	7' - 0" (off) x 7'-0" (high)
Floor to Bottom of Grid	56' - 3"	
Front of Apron to Plaster line	3' - 0"	(pit down)
	11' - 0"	(pit up)
Distance from Apron to Seats at Center	14' - 0"	
Distance from Apron to Seats Left & Right	12' - 0"	

**Counterweight and Spot Line Fly Systems:**

Floor to Bottom of Grid	56' - 3"	
Maximum Batten Travel	53' - 0"	
<u>Batten Positions</u>	<u>Batten Length</u>	<u>Distance from Plaster Line</u>
Valance	36' - 0"	0' - 8"
Main House Curtain	36' - 0"	1' - 2"
#1 Working	40' - 0"	1' - 9"
#2 1st Electric	40' - 0"	2' - 10"
#3 Working	42' - 0"	3' - 8"
#4 1st Orchestra Shell	40' - 0"	4' - 4"
#5 Working	40' - 0"	4' - 9½"
#6 Working	42' - 0"	5' - 3½"
#7 Working Legs	42' - 0"	5' - 6½"
#8 Movie Screen	40' - 0"	6' - 5½"
#9 Working	40' - 0"	7' - 4"
#10 Working [shell us pipe] Border	40' - 0"	7' - 10"
#11 Working	40' - 0"	8' - 4"
#12 2nd Electric	40' - 0"	9' - 4½"
#13 2nd Orchestra Shell	40' - 0"	10' - 4½"

#15	Working	42' - 0"	11' - 4"
#16	Working	42' - 0"	11' - 9"
#17	Working Legs	40' - 0"	12' - 2"
#18	Working	42' - 0"	12' - 9½"
#19	Working	42' - 0"	13' - 3"
#20	Working [shell us pipe] Border	40' - 0"	13' - 9½"
#21	Working	42' - 0"	14' - 8"
#22	3rd Electric	40' - 0"	15' - 4"
#23	3rd S Orchestra Shell	40' - 0"	16' - 6½"
#24	Working	42' - 0"	16' - 11"
#25	Working	42' - 0"	17' - 4"
#26	Working Legs	42' - 0"	17' - 9½"
#27	Working	42' - 0"	18' - 3"
#28	1st Hempset (4 line spotline)	41' - 1"	18' - 9"
#29	2nd Hempset (4 line spotline)	42' - 0"	19' - 3½"
#30	Working [shell us pipe] Border	40' - 0"	19' - 8"
#31	Working	42' - 0"	20' - 3"
#32	Working	42' - 0"	20' - 8"
#33	4th/Cyc Electric	40' - 0"	22' - 2"
3rd	Hempset (4 line spotline)	42' - 0"	23' - 4½"
4th	Hempset (4 line spotline)	42' - 0"	23' - 10½"
5th	Hempset (4 line spotline)	42' - 0"	24' - 4½"
6th	Hempset (4 line spotline)	42' - 0"	24' - 8½"
7th	Hempset (4 line spotline)	42' - 0"	25' - 2½"
8th	Hempset (4 line spotline)	42' - 0"	25' - 7½"
#34	Cyclorama	42' - 0"	26' - 7½"
9th	Hempset (4 line spotline)	42' - 0"	27' - 1½"
Down stage leg of Radiator on back wall to Plaster line			27' - 4"
Back Wall of Theatre to Plaster line			28' - 8"
Borders on sets		#10, #20, #30	
Legs on sets		#7, #17, #26	
Orchestra shells in stored position on sets		#4, #13, and #23	

**Equipment Available for Rent:**

10 - 3 foot x 8 foot Risers	8 inches - 16 inches - 2 foot legs available
10 - 4 foot x 8 foot Risers	8 inches - 16 inches - 2 foot legs available
6 - 4 foot x 6 foot Risers	8 inches - 16 inches - 2 foot legs available
Xenon Super Trouper Follow spots (2)	\$150.00/show per unit.

**Facility Costs:**

	Contact	Cost
Forklift	In house	\$100.00 Per day (operator not included)
Follow-spot lights	In house	\$150.00 per performance per unit
Barricade (blow through)	In house	\$25.00 per section plus labor
Internet	In house	\$200.00
Utilities	In House	\$200.00
Medical	In house	\$60.00/hour

Parking meter bags	In house	\$12.00 per meter (or current rate)
Clean-up		\$200.00 - \$500.00
Confetti Clean-up		\$250.00-\$500.00
Firemen	Not required	\$50.00

**Catering:** In House Food and Beverage Manager

<b><u>Staffing:</u></b>	Contact	Cost
Police	Nick Farfan	\$55.00
Security (Uniforms)	Same	\$45.50
Security (T-shirt)	Same	\$20.00
House Manager	Same	\$18.00
Ushers	Same	\$18.00
Ticket Seller	Same	\$18.00

**Stagehands:** Stagehands are IATSE Union members.

Technical Manager	\$35.00
Stagehands	\$30.00 - 4 hr. minimum
Loaders	\$30.00 - 4 hr. minimum
Forklift Operator	\$35.00 - 4 hr. minimum
Riggers	\$47.00 - 4 hr. minimum
Electrician	\$31.00 – 4 hr. minimum
Performance:	
Deckmen	\$30.00 - 4 hr. minimum
Follow-spot Operators	\$31.00 - 4 hr. minimum
Camera Operators	\$31.00 - 4 hr. minimum
Wardrobe	\$31.00 - 4 hr. minimum
Hair/Make-up	\$35.00 - 4 hr. minimum



4th St. ↑  
↓

Show Parking

Load In Door

Scene Shop

Obstruction

Piano Box

Ramp

Back Wall Obstruction

Company Switch  
Down Spiral  
Stairs

Stage Door

Radiators

Drain Pipes

Radiators

Radiators

House Cleaners  
Disconnect

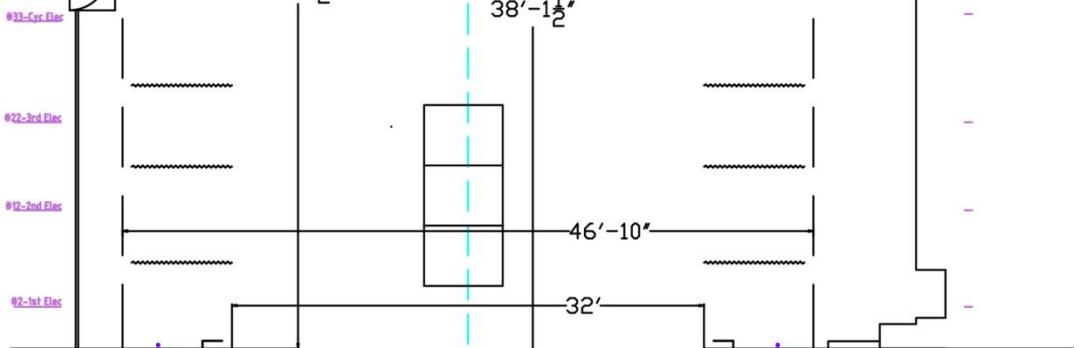

Pit Cover at  
Stage Level

# Three Price House

