

# Rodeo Arena

# EVENT CENTER

Arapahoe County Fairgrounds and Park

Daily Rental:  
7 a.m.-10 p.m.

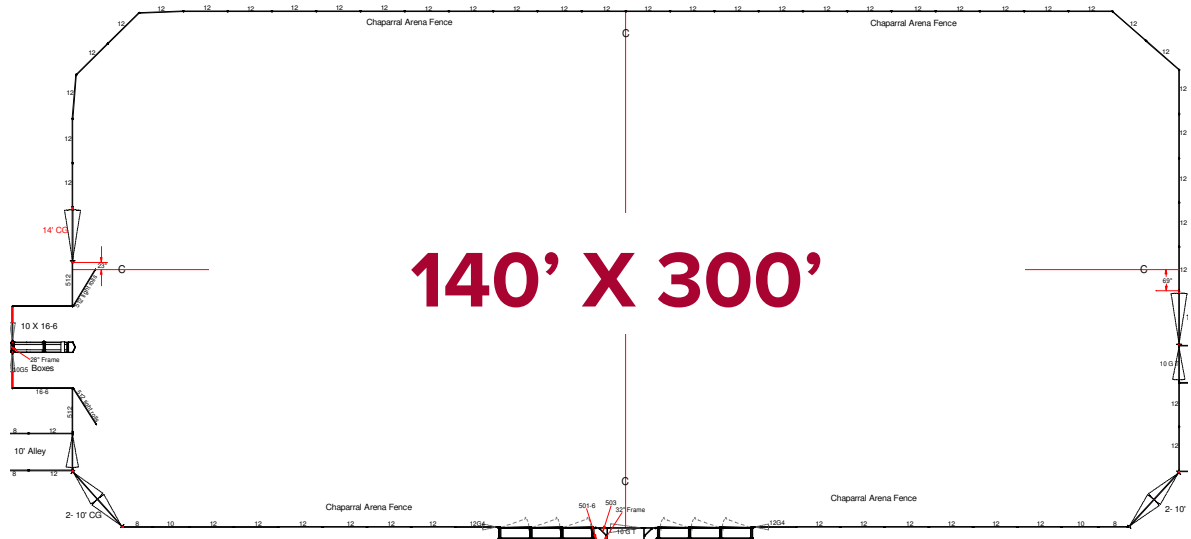

ARAPAHOE COUNTY  
OPEN SPACES

## Book Today

Book your next event at the  
**Arapahoe County Fairgrounds Event Center**  
[www.arapahoecountyeventcenter.com](http://www.arapahoecountyeventcenter.com)  
25690 E. Quincy Ave., Aurora, CO 80016

## Contact:

303-795-4955  
[fairgrounds@arapahoegov.com](mailto:fairgrounds@arapahoegov.com)





## Rodeo Arena Guidelines

Event: \_\_\_\_\_ Date(s): \_\_\_\_\_

Our goal at the Fairgrounds is to support customer's needs while minimizing the negative impact on the facilities leaving the facility in good condition. To help us achieve this, please follow the guidelines below:

- The following items are included in your rental:
  - One (1) Daily drag/water of arena floor( Only if it is scheduled ahead of time) - additional grooming charges may apply
  - Large arena floor 150' x 300'
  - One (1) Roping Chute
  - Six (6) Bucking Chutes
  - Two (2) Roping Boxes
  - One (1) Squeeze Chute
  - One (1) Loading Chute
  - Twenty-Four (24) Holding Pens – various sizes ranging from 10 x 10 to 20 x 25
  - Elevated Announcer Shed with PA system
  - Access to two (2) portalets- includes one (1) service/day
- Additional items available for rent:
  - Forty (40) 10 x 10 Horse Stalls
  - Additional holding pens
  - Bleachers seating up to 1,200 spectators
  - Hard packed arena flooring
  - Access to RV sites (electrical only, rates may vary, pending availability)

\*\* Note: there is not lighting in this area
- Rodeo Events to be excluded with no exceptions:
  - Steer Tailing
  - Horse Tripping
  - Forefooting
  - Forefooting on Horseback
- For events greater than 100 people, additional portalet rental and servicing charges may be applied. Fairgrounds staff to coordinate rental and servicing of portalet.
- Liquor sales permitted with necessary permit through Arapahoe County. Alcohol is not allowed in the arena.
- No outside grooming equipment is permitted on the Fairgrounds unless approved through Fairgrounds Staff.
- No spectators inside of the arena; participants only allowed inside of the arena. This includes chair seating and standing room. Bleachers are only to be set up outside of the arena. No standing on exterior paneling.
- This excludes staff and/or participants. All other seating must be outside of the arena. Bleachers are only to be set up outside of the arena. No standing on exterior paneling.
- Event Holder is responsible for removing any animal waste from both the arena and grounds following their event.
- Confetti, birdseed, rice, glitter or similar small items are not permitted. Failure to do so, will be subject to additional fees.
- Hay, straw, shavings and like items are not permitted on the arena floor. However, any of these items used on the outside grounds, the Event Holder is responsible for removing and cleaning those areas.
- Live musical acts are permitted with prior approval from Fairgrounds Staff. Staging not provided.
- No food is permitted inside the arena. Food can be set up on the exterior grounds only.
- Smoking is not allowed in any County building. Smokeless tobacco is also not allowed in any County building.
- Liquid petroleum (Propane, butane, etc.), hazardous materials (wet cell batteries, fuel, gunpowder) are not allowed.
- There is limited electrical onsite. For additional needs, please see Fairgrounds Staff.
- All trailers need to be parked north of the Covered Arena.
- All vehicles need to be parked in designated parking lots only.
- Fireworks and like items are not allowed onsite unless approved through South Metro Fire and Fairgrounds Staff.

It is understood that these guidelines are in addition to the Fairgrounds Policy Statement and are not all-inclusive.

I have read and understand the Covered Arena guidelines listed above. I understand that if the guidelines are not followed, a financial penalty may be incurred or future use of the facility denied.

Event Holder: \_\_\_\_\_ Date: \_\_\_\_\_