

2025

**FORT WORTH  
STOCK SHOW  
& RODEO**

A decorative flourish consisting of a long, sweeping curve that starts under the 'R' of 'RODEO' and extends to the right, ending in a small hook.

**Pattern Book**

NRCHA & AQHA Working Cow  
Horse Classes

**PATTERN 12**

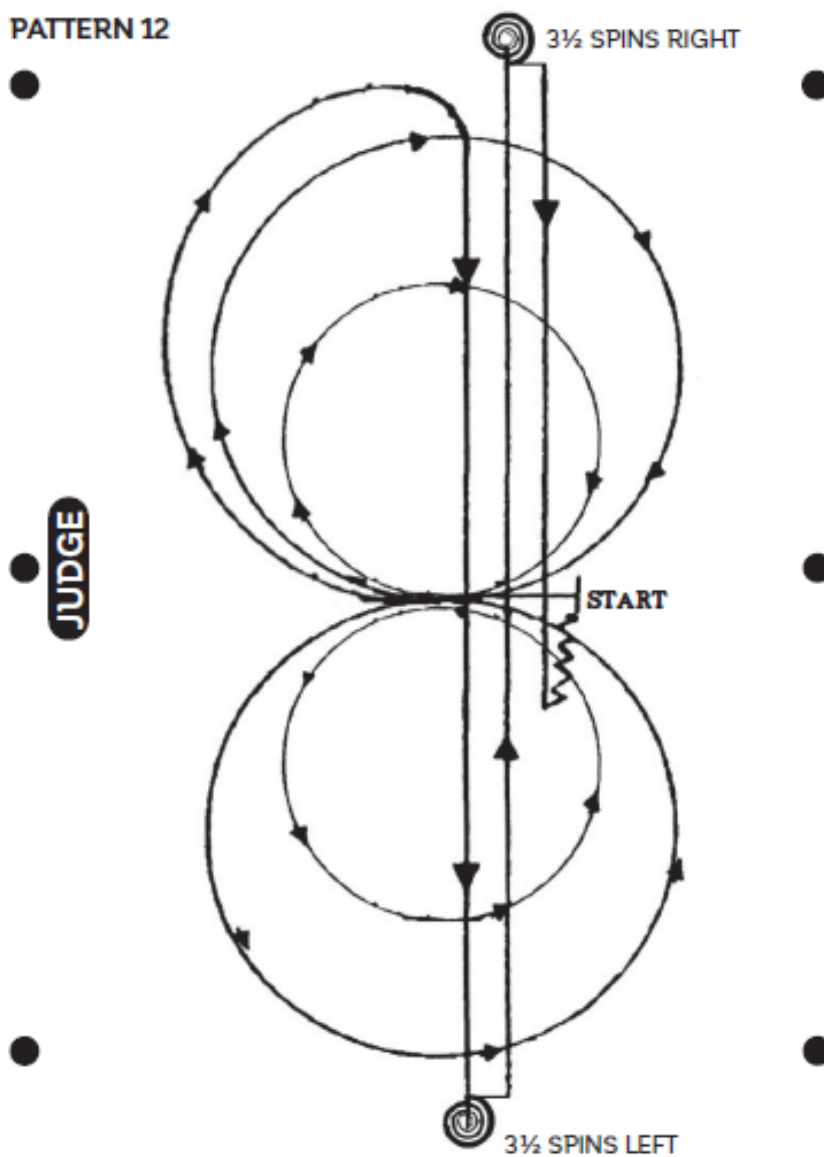

Trot to center of arena, stop. Start pattern facing towards judge.

1. Beginning on the right lead complete two circles to the right, the first circle large and fast, and the second circle small and slow. Change leads at the center of the arena.
2. Complete two circles to the left, the first circle large and fast, and the second circle small and slow. Change leads at the center of the arena.
3. Continue around end of arena without breaking gait or changing leads, run down center of the arena past the end marker, execute a square sliding stop.
4. Complete 3 1/2 spins to the left.
5. Run down center of arena past end marker, execute a square sliding stop.
6. Complete 3 1/2 spins to the right.
7. Run down center of arena past center marker, execute a square sliding stop. Back at least 10 feet. Hesitate to complete pattern.

\*This pattern may be used as a lope in pattern, please refer to rule 20.6

**PATTERN 4** May be used for NHSRA Events

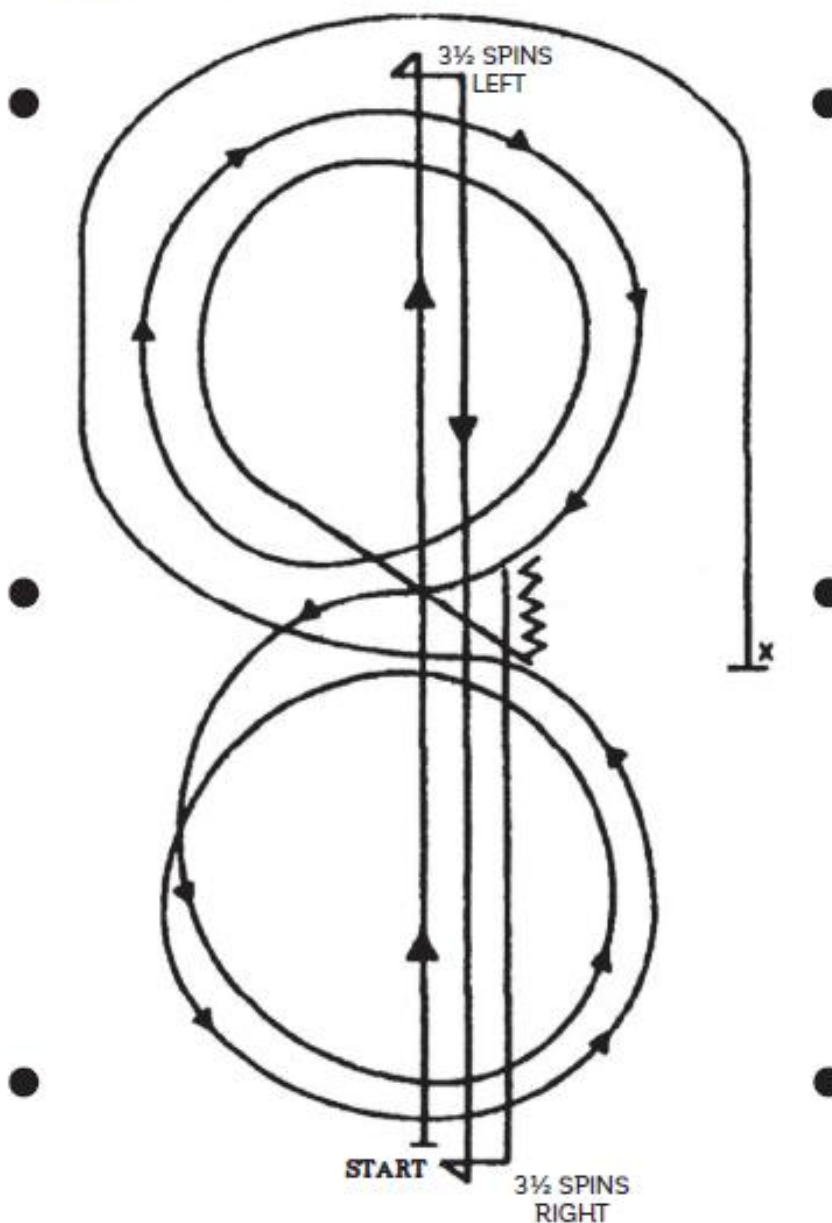

1. Start at end of arena. Run up center of arena past the end marker and come to a sliding stop.
2. Complete  $3\frac{1}{2}$  spins to the left.
3. Run to other end of arena past the end marker and stop.
4. Complete  $3\frac{1}{2}$  spins to the right.
5. Run past the center marker and stop. Back at least 10 feet in a straight line. Complete a  $\frac{1}{4}$  turn to the left.
6. Beginning on the right lead, complete two circles to the right, the first one small and slow, and the second large and fast. Change leads at the center of the arena.
7. Complete one small and slow circle and one large and fast circle. Change leads to the right.
8. Run around end of arena to the other side, past center marker, at least 20 feet from fence and come to sliding stop. Hesitate to complete pattern.

**PATTERN 4** May be used for NHSRA Events

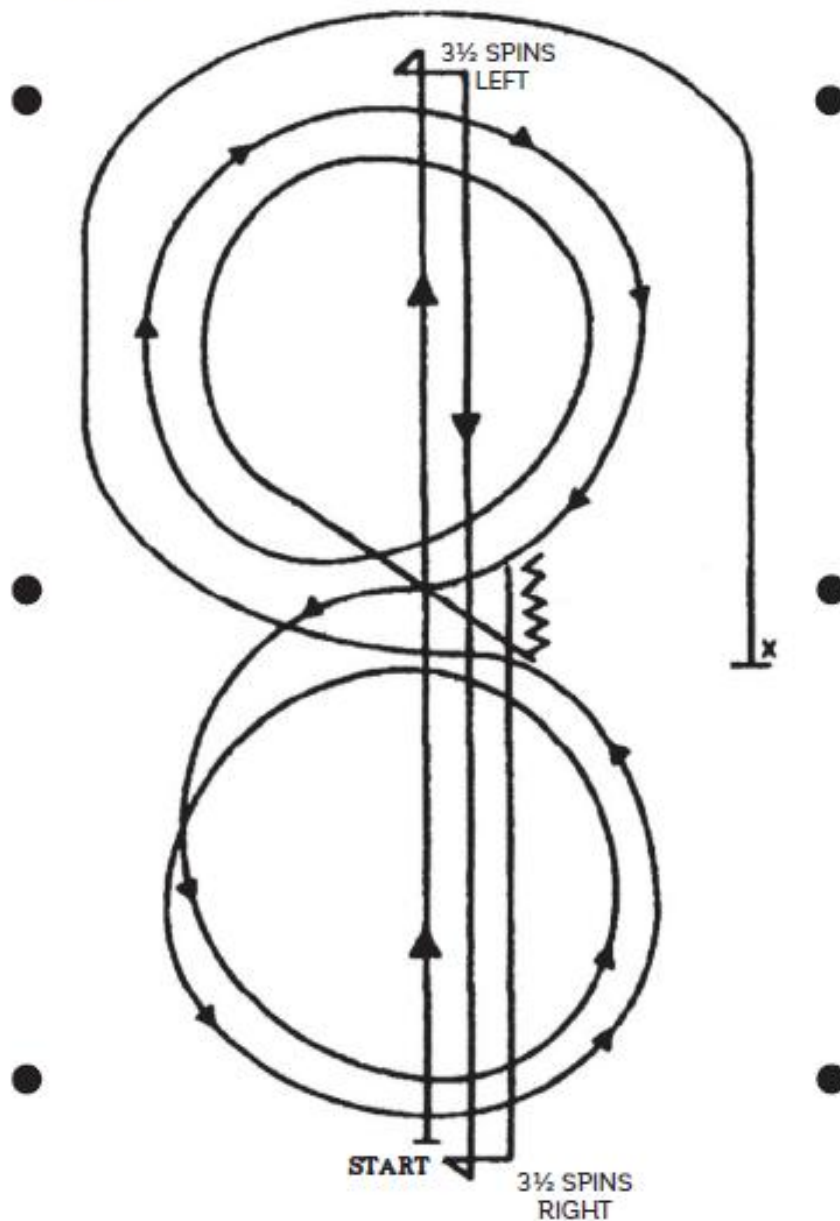

1. Start at end of arena. Run up center of arena past the end marker and come to a sliding stop.
2. Complete  $3\frac{1}{2}$  spins to the left.
3. Run to other end of arena past the end marker and stop.
4. Complete  $3\frac{1}{2}$  spins to the right.
5. Run past the center marker and stop. Back at least 10 feet in a straight line. Complete a  $\frac{1}{4}$  turn to the left.
6. Beginning on the right lead, complete two circles to the right, the first one small and slow, and the second large and fast. Change leads at the center of the arena.
7. Complete one small and slow circle and one large and fast circle, Change leads to the right.
8. Run around end of arena to the other side, past center marker, at least 20 feet from fence and come to sliding stop. Hesitate to complete pattern.

**PATTERN 12**

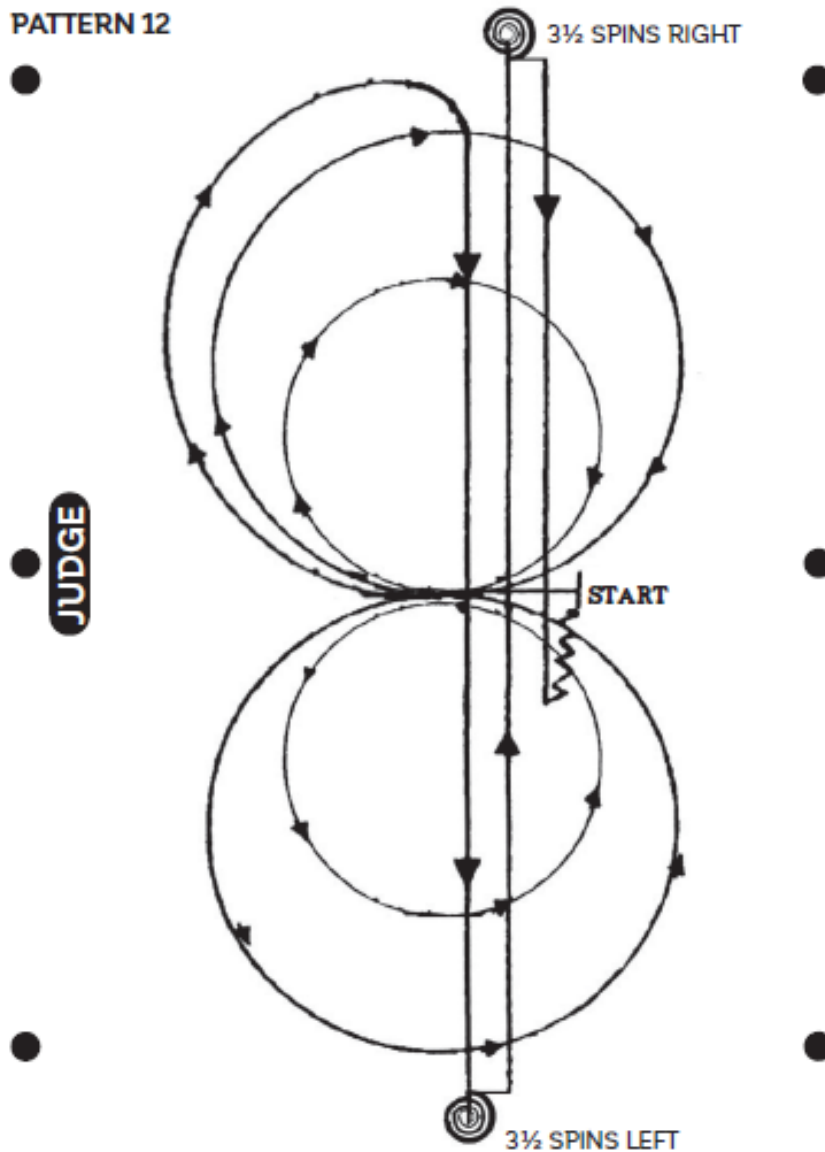

Trot to center of arena, stop. Start pattern facing towards judge.

1. Beginning on the right lead complete two circles to the right, the first circle large and fast, and the second circle small and slow. Change leads at the center of the arena.
2. Complete two circles to the left, the first circle large and fast, and the second circle small and slow. Change leads at the center of the arena.
3. Continue around end of arena without breaking gait or changing leads, run down center of the arena past the end marker, execute a square sliding stop.
4. Complete 3 1/2 spins to the left.
5. Run down center of arena past end marker, execute a square sliding stop.
6. Complete 3 1/2 spins to the right.
7. Run down center of arena past center marker, execute a square sliding stop. Back at least 10 feet. Hesitate to complete pattern.

\*This pattern may be used as a lope in pattern, please refer to rule 20.6



**PATTERN 4** May be used for NHSRA Events

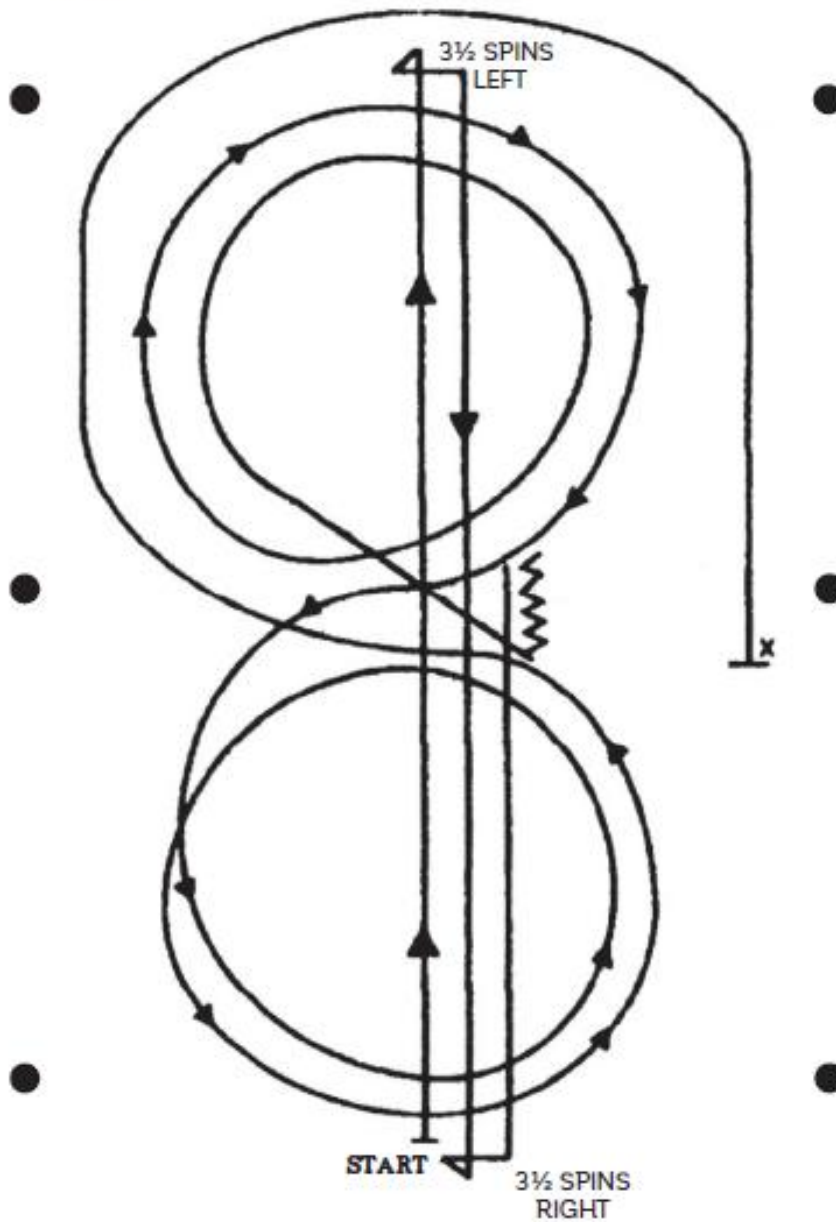

1. Start at end of arena. Run up center of arena past the end marker and come to a sliding stop.
2. Complete  $3\frac{1}{2}$  spins to the left.
3. Run to other end of arena past the end marker and stop.
4. Complete  $3\frac{1}{2}$  spins to the right.
5. Run past the center marker and stop. Back at least 10 feet in a straight line. Complete a  $\frac{1}{4}$  turn to the left.
6. Beginning on the right lead, complete two circles to the right, the first one small and slow, and the second large and fast. Change leads at the center of the arena.
7. Complete one small and slow circle and one large and fast circle, Change leads to the right.
8. Run around end of arena to the other side, past center marker, at least 20 feet from fence and come to sliding stop. Hesitate to complete pattern.

**PATTERN 4** May be used for NHSRA Events

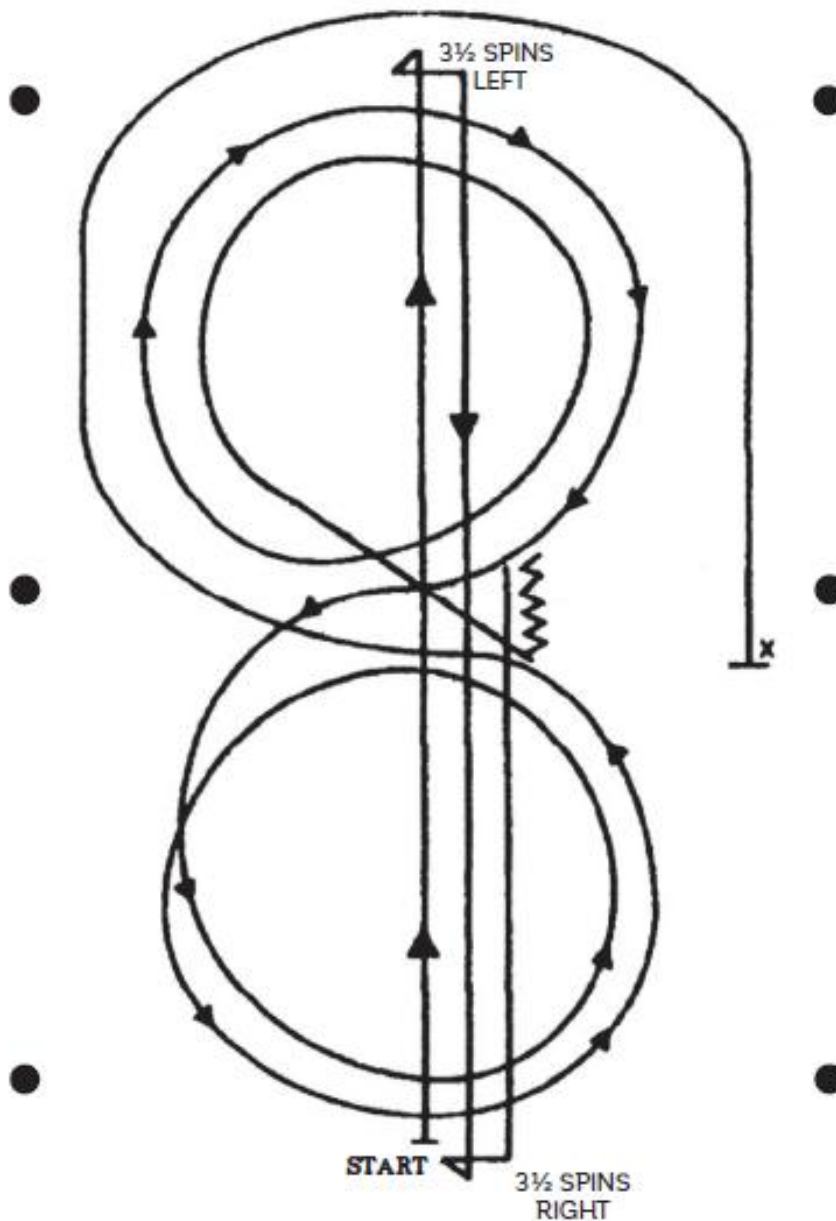

1. Start at end of arena. Run up center of arena past the end marker and come to a sliding stop.
2. Complete  $3\frac{1}{2}$  spins to the left.
3. Run to other end of arena past the end marker and stop.
4. Complete  $3\frac{1}{2}$  spins to the right.
5. Run past the center marker and stop. Back at least 10 feet in a straight line. Complete a  $\frac{1}{4}$  turn to the left.
6. Beginning on the right lead, complete two circles to the right, the first one small and slow, and the second large and fast. Change leads at the center of the arena.
7. Complete one small and slow circle and one large and fast circle, Change leads to the right.
8. Run around end of arena to the other side, past center marker, at least 20 feet from fence and come to sliding stop. Hesitate to complete pattern.

Class 1161 – AQHA Junior Working Cow Horse, 5 years & under

Class 1 – NRCHA Open Hackamore

Class 2 – NRCHA Limited Open Hackamore

**PATTERN 12**

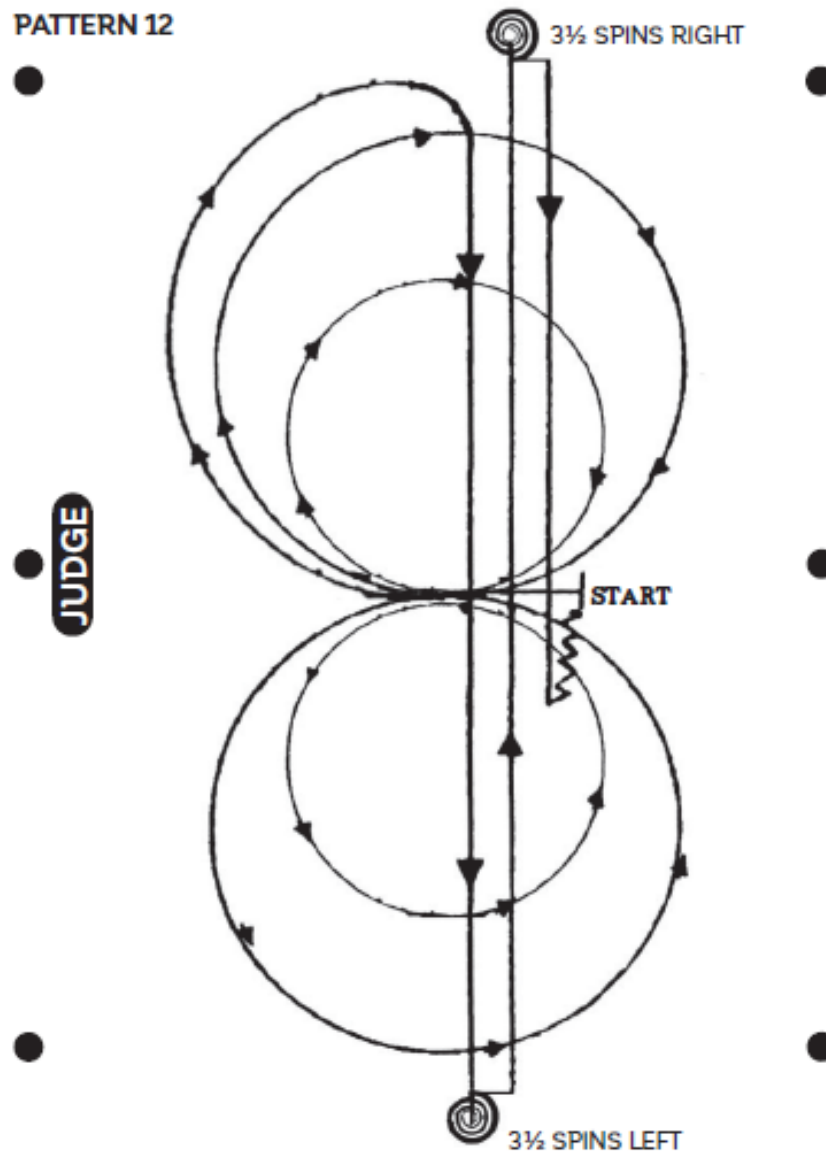

Trot to center of arena, stop. Start pattern facing towards judge.

1. Beginning on the right lead complete two circles to the right, the first circle large and fast, and the second circle small and slow. Change leads at the center of the arena.
2. Complete two circles to the left, the first circle large and fast, and the second circle small and slow. Change leads at the center of the arena.
3. Continue around end of arena without breaking gait or changing leads, run down center of the arena past the end marker, execute a square sliding stop.
4. Complete 3 1/2 spins to the left.
5. Run down center of arena past end marker, execute a square sliding stop.
6. Complete 3 1/2 spins to the right.
7. Run down center of arena past center marker, execute a square sliding stop. Back at least 10 feet. Hesitate to complete pattern.

\*This pattern may be used as a lope in pattern, please refer to rule 20.6



Class 1162 – AQHA Senior Working Cow Horse, 6 years & over

Class 3 – NRCHA Open Bridle

Class 4 – NRCHA Limited Open Bridle

**PATTERN 12**

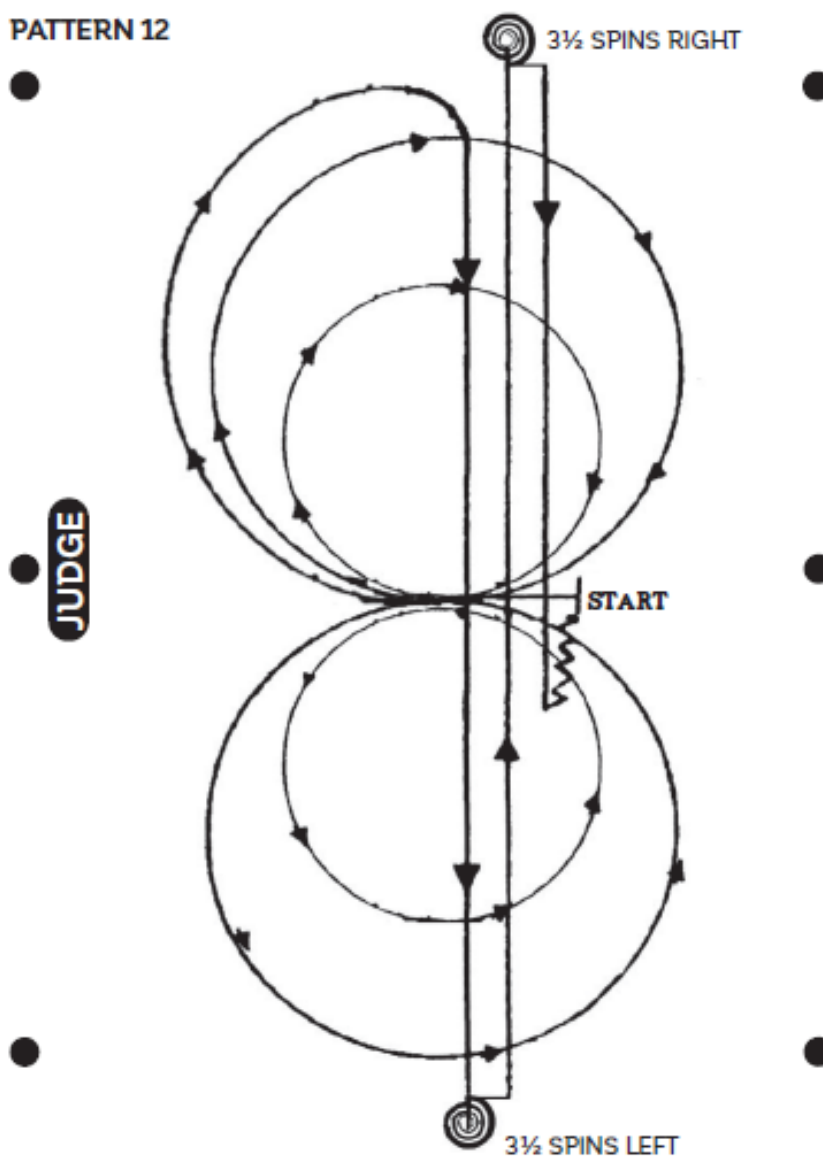

Trot to center of arena, stop. Start pattern facing towards judge.

1. Beginning on the right lead complete two circles to the right, the first circle large and fast, and the second circle small and slow. Change leads at the center of the arena.
2. Complete two circles to the left, the first circle large and fast, and the second circle small and slow. Change leads at the center of the arena.
3. Continue around end of arena without breaking gait or changing leads, run down center of the arena past the end marker, execute a square sliding stop.
4. Complete 3½ spins to the left.
5. Run down center of arena past end marker, execute a square sliding stop.
6. Complete 3½ spins to the right.
7. Run down center of arena past center marker, execute a square sliding stop. Back at least 10 feet. Hesitate to complete pattern.

\*This pattern may be used as a lope in pattern, please refer to rule 20.6

**PATTERN 12**

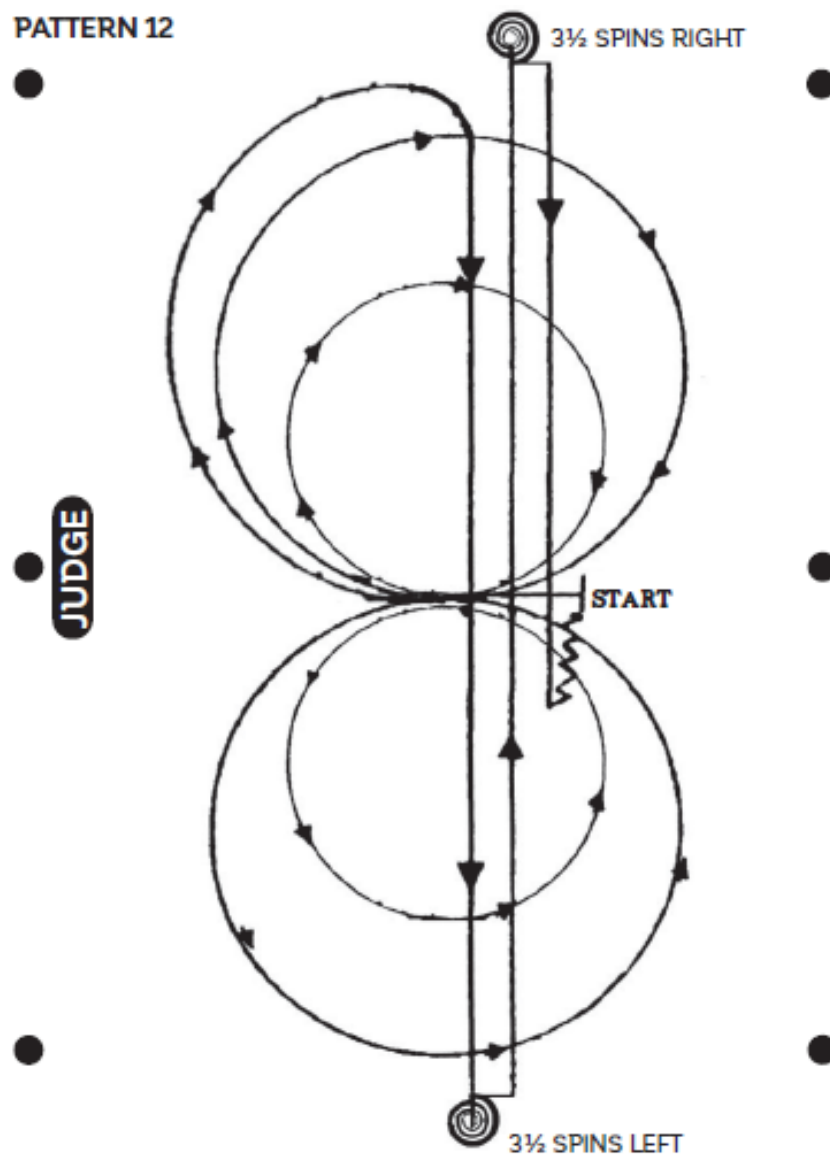

Trot to center of arena, stop. Start pattern facing towards judge.

1. Beginning on the right lead complete two circles to the right, the first circle large and fast, and the second circle small and slow. Change leads at the center of the arena.
2. Complete two circles to the left, the first circle large and fast, and the second circle small and slow. Change leads at the center of the arena.
3. Continue around end of arena without breaking gait or changing leads, run down center of the arena past the end marker, execute a square sliding stop.
4. Complete 3½ spins to the left.
5. Run down center of arena past end marker, execute a square sliding stop.
6. Complete 3½ spins to the right.
7. Run down center of arena past center marker, execute a square sliding stop. Back at least 10 feet. Hesitate to complete pattern.

\*This pattern may be used as a lope in pattern, please refer to rule 20.6