



FAMILY, CAREER AND COMMUNITY LEADERS OF AMERICA
AT THE GEORGIA NATIONAL FAIR

Family, Career and Community Leaders of America is a national student organization which functions as an integral part of the Family and Consumer Sciences curriculum in Georgia schools. FCCLA encourages personal growth, prepares for careers, fosters family and community involvement and helps students become leaders. Through programs such as Career Connection, students prepare for the world of work. Programs such as Families First and Families Acting for Community Traffic Safety reinforce the importance of a strong home life. The Community Service, Stand Up program and the Japanese Exchange Program provide incentives to developing local, national, even global, community ties. The Power Of One, Student Body and Financial Fitness program encourage members to make positive lifestyle choices and practice goal setting. Leadership skills are enhanced through opportunities to serve as local, state and national officers. Conferences such as state and national leadership meetings and regional cluster meetings provide intense leadership training and the chance to network with teens who have similar interests and concerns. Through the STAR Events program, members are recognized for proficiency and achievement in leadership and career skills. FCCLA is The Ultimate Leadership Experience!

The mission of FCCLA is to promote personal growth and leadership development through Family and Consumer Sciences education. Focusing on the multiple roles of family member, wage earner and community leader, members develop skills for life through character development, creative and critical thinking, interpersonal communication, practical knowledge and career preparation.

Open to all bona fide FCCLA members in the state of Georgia. Entries may be made as individuals or teams, as specified in the rules for each competition and must be submitted through the chapter advisor.



www.GeorgiaNationalFair.com

Chapters must have submitted their affiliation for the current school year to the state and national offices to be eligible to participate. Each participating member must be listed on the affiliation system. Affiliation information is available on the state website at:

www.gafccla.com

GEORGIA NATIONAL FAIR FCCLA SUPERIOR CHAPTER AWARD

1st Place - Superior Chapter - \$500

2nd Place - Reserve Superior Chapter - \$250

Sponsored by the Georgia National Fair

All placings will be put on a point system: 1st place=20 pts., 2nd place=15 pts., 3rd place=10 pts., 4th place=5 pts. These points will be calculated by chapter and the chapter with the highest accumulated points after the last competition will receive a GNF Superior Chapter Award plaque and \$500. The second place chapter will receive a GNF Reserve Superior Chapter Award plaque and \$250.

Congratulations!

**2022 Georgia National Fair
FCCLA Superior Chapter**

Liberty Middle School (Covington)

Reserve Superior Chapter

Northside Middle School

1. **ALL EXHIBITORS ARE REQUIRED TO READ AND ABIDE BY THE GEORGIA NATIONAL FAIR GENERAL RULES AND REGULATIONS. PLEASE NOTE: IT IS YOUR RESPONSIBILITY TO READ AND UNDERSTAND THE RULES. IF YOU HAVE QUESTIONS, YOU MAY CERTAINLY EMAIL US AT contests@gnfa.com. PLEASE HELP US PREVENT ENTRY DISQUALIFICATIONS.**
2. These competitions are open to all bona fide FCCLA members in the state of Georgia.
3. **Advisors must email contests@gnfa.com to obtain required password, which must be obtained by Sept. 18, 2023. Enter online at <https://www.georgianationalfair.com/p/georgialiving/youth> by September 20, 2023. No substitutions allowed. Late entries will not be processed.**
4. Exhibitors will be required to turn in a copy of their online registration confirmation to check-in for competitions.

ONLINE REGISTRATION

You will log in as your “club”, but all contests will be entered in the Chapter/Club name.

When you add the exhibitor, you will enter the SCHOOL NAME in the first name field and FCCLA in the last name field. You will add all entries under this one exhibitor name. Individual student names must be entered in the Student Name field.

Participant names must be entered in the Student Name field for each entry to be able to track premium awards.

FCCLA SCHEDULE OF EVENTS

Deadline for entry registration - Wednesday, Sept. 20.

Fri., Sept. 22

Postmark deadline for T-shirt entries

Sat., Sept. 23; Mon. & Tues., Sept. 25-26

Chapter Booth Setup (**Heritage Hall**)

Saturday 10:00 AM - 3:00 PM

Weekdays 9:00 AM - 5:00 PM

Tue., Oct. 10

1:00 PM Chili Cook-off Middle School
Miller-Murphy-Howard Building, North End of Building

3:00 PM Chili Cook-off High School
Miller-Murphy-Howard Building, North End of Building

Wed., Oct. 11

10:30-11:00 AM Georgia FCCLA Peanut Recipe Contest Receiving of Entries
Heritage Hall Kitchen

1:00 PM Theme Speech Competition
Heritage Hall Stage

1:15 PM Culinary Competition
Miller-Murphy-Howard Building, North End of Building

Tues., Oct. 17, 12:00 PM - Release of entries begins
There will be no early release of entries.

FCCLA CHAPTER T-SHIRT COMPETITION

Coordinator Caitlin Roberson
770-530-1874 • croberson@gafccla.com

ALL EVENTS MUST BE ENTERED with the School Name in the “First Name” field and “FCCLA” in the “Last Name” field. (Example: First Name “Best High School” and Last Name “FCCLA”) and individual names must be listed in the Student Name field.

Enter online at www.GeorgiaNationalFair.com
(<https://www.georgianationalfair.com/p/georgialiving/youth>) by **September 20, 2023.**

DIVISION 20101 - FCCLA CHAPTER T-SHIRT COMPETITION

CLASS

01 FCCLA Chapter T-shirt Competition

<u>1st</u>	<u>2nd</u>	<u>3rd</u>	<u>4th</u>
\$100	\$75	\$50	\$25

A copy of the online registration confirmation will be required to check-in for competition.

PROCEDURES:

1. Advisors/Students must submit their small T-shirt and essay Georgia FCCLA via USPS, FedEx or UPS. All shipments must be postmarked by September 23, 2022. Any entries received after this day will not be considered.

Georgia FCCLA
P.O. Box 840
Bogart, GA 30622

2. Georgia FCCLA will deliver the top ten T-shirts to the Georgia National Fairgrounds prior to the opening of the Fair for display.

CONTEST RULES:

1. **ALL EXHIBITORS ARE REQUIRED TO READ AND ABIDE BY THE GEORGIA NATIONAL FAIR GENERAL RULES AND REGULATIONS. PLEASE NOTE: IT IS YOUR RESPONSIBILITY TO READ AND UNDERSTAND THE RULES. IF YOU HAVE QUESTIONS, YOU MAY CERTAINLY EMAIL US AT: contests@gnfa.com. PLEASE HELP US PREVENT ENTRY DISQUALIFICATIONS.**

2. Entries are limited to one per chapter.

3. The chapter must submit 1 small size T-shirt.

4. Chapters must also submit a 100-150 word essay that explains the T-shirt's design and how it represents the chapter.

4. The FCCLA logo must be incorporated into the design. The logo may either be the FCCLA national logo, state logo or chapter logo. Proper guidelines for logo use can be found at: <https://fcclainc.org/communications/branding-guidelines>.

5. The T-shirt must have the current school year: 2023-2024.

6. Chapters are strongly encouraged to wear their Chapter T-shirt to the Fall Leadership Rally.

7. One (1) chapter representative from each chapter entered into the event will have reserved seating at the front of the stage during our General Session. The top 10 winners will be recognized on stage.

8. The top entries will be displayed during the Georgia National Fair. Entries must remain on display for the

duration of the Fair. Early removal of exhibits will result in forfeiture of premiums and possible disqualification from future competition.

9. Submitted Chapter T-shirts will not be returned. Rubrics will not be released.

EVALUATION:

Chapter T-shirt (70 points)

General Effect / Impact (20 points)

- Effectively represents local chapter
- Overall visual appearance

Design Elements (20 points)

- Use of Graphics to enhance T-shirt
- Text (Readability, Grammar, Spelling, etc)
- Colors Used

Uniqueness / Creativity of Design (20 points)

Logo Incorporation (10 points)

Written Essay (30 points)

Content

Organization

Grammar, Usage & Mechanics

FCCLA BROCHURE

Coordinator Caitlin Roberson
770-530-1874 • croberson@gafccla.com

ALL EVENTS MUST BE ENTERED with the School Name in the “First Name” field and "FCCLA" in the “Last Name” field. (Example: First Name “Best High School” and Last Name “FCCLA”) and individual names must be listed in the Student Name field.

Enter online at www.GeorgiaNationalFair.com
(<https://www.georgianationalfair.com/p/georgialiving/youth>) by **September 20, 2023**.

BROCHURES MUST BE SUBMITTED BY SEPTEMBER 24. Only one entry per school total. No late entries will be accepted for any reason. Submit your brochure at: <https://gafccla.wufoo.com/forms/fall-rally-brochure-competition-submission/>.

DIVISION 2023 FCCLA BROCHURE MIDDLE SCHOOL
DIVISION 2024 FCCLA BROCHURE HIGH SCHOOL (GRADES 9-12)

CLASS

- 01 General FCCLA Information (to provide to business and industry partners)
- 02 Georgia FCCLA Foundation Sponsor Recruitment
- 03 Male Chapter Member Recruitment
- 04 One National Program or State Program

<u>1st</u>	<u>2nd</u>	<u>3rd</u>	<u>4th</u>
\$100	\$75	\$50	\$25

CONTEST RULES:

1. **ALL EXHIBITORS ARE REQUIRED TO READ AND ABIDE BY THE GEORGIA NATIONAL FAIR GENERAL RULES AND REGULATIONS. PLEASE NOTE: IT IS YOUR RESPONSIBILITY TO READ AND UNDERSTAND THE RULES. IF YOU HAVE QUESTIONS, YOU MAY CERTAINLY EMAIL US AT: contests@gnfa.com. PLEASE HELP US PREVENT ENTRY DISQUALIFICATIONS.**
2. Entries are limited to one entry total per chapter (i.e. one entry in Foundation Sponsor Recruitment, OR one in National Program or State Program, etc.).
3. Entries must be the original work of the local chapter. Copy-ready brochures provided by the state or national offices are not acceptable. Official logos may be used, however.
4. Entries must be formatted to print on 8 1/2 x 11 inch paper. They may be trifold brochures or they may be duofold (booklet type) brochures. Each brochure is limited to two sides (front and back if printed).
5. Brochures may be color or black and white.
6. Brochures must be submitted in **PDF format**. Entries that are not submitted in this format will be disqualified.
7. Brochures will be judged on:
 - a. Effectiveness of the message
 - b. Incorporation of the current National Theme
 - c. Page layout, principles used in design, clip art selection and placement, font selection and usage
 - d. Creativity of the Presentation
 - e. General Appearance (Neatness, legibility, balance)
 - f. Accuracy and Appeal of information provided
8. Entrants agree to permit the use of their brochure to promote FCCLA in Georgia should GA FCCLA elect to use the brochure entry for that purpose.
9. Winners will be announced during the Rally on Wednesday, October 11.
10. Submitted printed brochures will not be returned. Rubrics will not be released.

FCCLA CHAPTER BOOTH

ALL EVENTS MUST BE ENTERED with the School Name in the “First Name” field and "FCCLA" in the “Last Name” field. (Example: First Name “Best High School” and Last Name “FCCLA”) and individual names must be listed in the Student Name field.

Enter online at GeorgiaNationalFair.com

(<https://www.georgianationalfair.com/p/georgialiving/youth>) by September 20, 2023.

Chapter Booth Setup: Sat., Sept. 23; Mon. & Tues., Sept. 25-26; Saturday, 10:00 AM - 3:00 PM, weekdays 9:00 AM - 5:00 PM, HERITAGE HALL. Please allow ample time for set-up. The Building will close at 5:00 PM on weekdays and 3:00 PM on Saturday. You will not be able to stay past closing time, nor will you be allowed access to the building before 9:00 AM on weekdays or 10 AM on Saturday.

*****NO SUNDAY DELIVERY*****

The educational exhibits of the Georgia National Fair are designed to promote better understanding of the focus of Family and Consumer Sciences and the mission of the Georgia Association of Family, Career and Community Leaders of America.

DIVISION 20303 FCCLA CHAPTER BOOTH MIDDLE SCHOOL(GRADES 6-8)
DIVISION 20304 FCCLA CHAPTER BOOTH HIGH SCHOOL (GRADES 9-12)

CLASS
01 Chapter Booth

First Place.....GNF \$300 & Rosette
 Second Place.....GNF \$250 & Rosette
 Third Place.....GNF \$200 & Rosette
 Fourth Place.....GNF \$150 & Rosette

A copy of the online registration confirmation will be required to check-in for competition.

CONTEST RULES:

1. **ALL EXHIBITORS ARE REQUIRED TO READ AND ABIDE BY THE GEORGIA NATIONAL FAIR GENERAL RULES AND REGULATIONS. PLEASE NOTE: IT IS YOUR RESPONSIBILITY TO READ AND UNDERSTAND THE RULES. IF YOU HAVE QUESTIONS, YOU MAY CERTAINLY EMAIL US AT: contests@gnfa.com. PLEASE HELP US PREVENT ENTRY DISQUALIFICATIONS.**
2. All Georgia affiliated FCCLA chapters are eligible to participate. **Please see box at the bottom of page 1 for additional instructions.**
3. A chapter may enter only one exhibit.
4. Application for exhibit space must be submitted by chapters registering online at **<https://www.georgianationalfair.com/p/georgialiving/youth>** by **September 20, 2023.**
5. Exhibits must be based on current FCCLA state or national programs or areas of skill development. The exhibit must be informative and well organized. Animation is encouraged to promote dramatization. Projects must be developed into an exhibit to accommodate a triangular space 4'x4'x5'6", with a two-sided backdrop of 4'x8' plywood panels hinged together, so that decorations of your choice may be stapled or thumb tacked to them. (Do not use glue or paint.) No alterations or cutting of booths will be permitted. Height of the exhibit must not exceed the height of the booth. These panels will be supplied by the Fair and will be in place ready for use by September 23. Use of the floor space within the triangle to create a three-dimensional exhibit is strongly encouraged. **The 12"x5'6" title board must be displayed across the top.** See sketch on next page. You are encouraged to pre-make displays designed to slide into the booth, but keep in mind that

they may not extend outside of the stated measurements. We recommend that any pre-made elements be made slightly smaller than approximate measurements of booth. Any spaces can be filled with borders, etc. Weight of materials should be considered, as they may have to be carried some distance.

6. **Please bring no more than five students to set up exhibit.**
7. All electrical or mechanical equipment included in the exhibit to create motion or action must be so well constructed that it will operate for the duration of the Fair. Electricity will be available; please be sure to indicate on your space application if you need booth electricity. (Electricity for glue gun, stapler, etc. will be provided.)
8. Title sign must state the theme of the exhibit, and all things used in the exhibit must contribute to the theme.
9. Signs announcing the name of the chapter must be covered until after the exhibits are judged.
10. **Entries that do not follow the guidelines will not place.**
11. **Chapters entering must assume all responsibility for placing and removing their exhibits.** All display apparatus such as placards, models and other articles are to be provided by the exhibitor.
12. **HERITAGE HALL will be open: Saturday, Sept. 23, 10:00 AM - 3:00 PM, and Mon. and Tues., Sept. 25-26, 9:00 AM - 5:00 PM for the arrangement of exhibits. There will be no set-up outside of these hours. ***NO SUNDAY DELIVERY*** CHAPTERS WILL BE ALLOWED TO SET UP ON ONE DAY ONLY; RETURN TRIPS TO MODIFY/ COMPLETE DISPLAYS WILL NOT BE ALLOWED.**
13. **There will be no Sunday evening exhibit release.** Exhibits must be removed Tuesday, October 17, between 12:00 PM and 8:00 PM, Wednesday, October 18, between 10:00 AM and 4:00 PM, or Saturday, October 21, between 10:00 AM and 3:00 PM. **All exhibits left after Saturday, October 21, 3:00 PM deadline will be discarded.** If for some reason you are unable to return to dismantle your display, please make arrangements with another advisor/volunteer to do so and notify GNF staff.
14. **CANCELLATIONS:** Please!! If you see that your chapter will not use the space you have reserved by pre-registration, call the Fair (478-988-6555) and leave a message for the FCCLA coordinator. Large exhibit spaces are difficult to deal with when left empty at Fair time. Thanks for your cooperation.
15. Rubrics will not be released.

Chapter Booth Dimensions

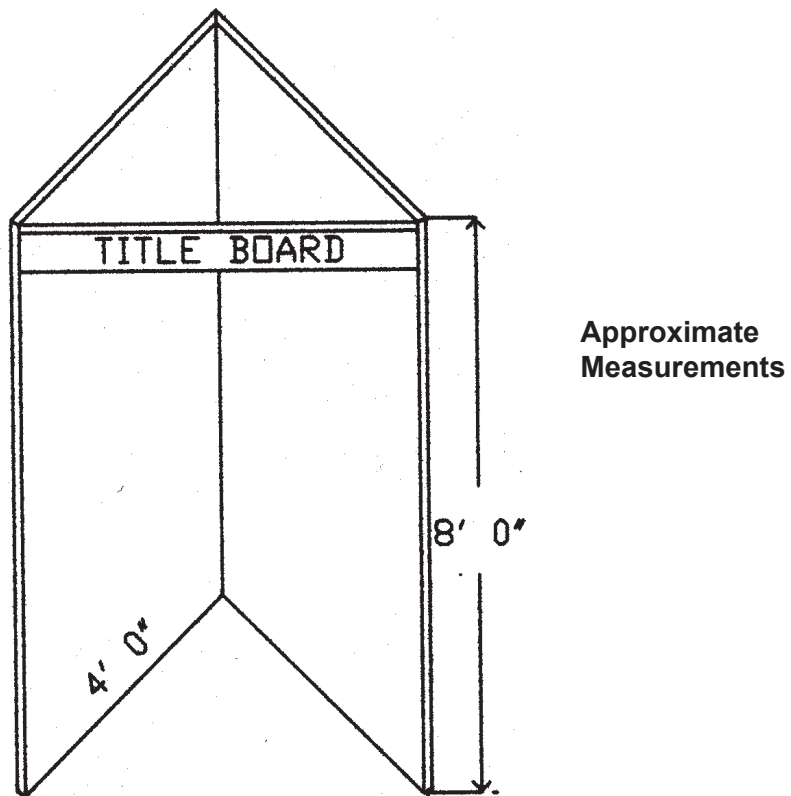

NOTE: The 12"x5'6" title board must be displayed across the top. Exhibits may not extend outside of the stated measurements.

Entries not following guidelines will not place.

The FCCLA Chapter Booth rating information: Each of the five main categories listed below receive equal weight, with a maximum of 5 points. Judges are asked to use decimal points in their scoring, e.g., 4.4, 3.8, to help avoid ties. **Note: Entries not following guidelines will not place.**

Presentation of Theme:

- *Used current state theme
- *Use of theme evident in all parts of the exhibit
- *Effective use of theme

Creativity of Presentation:

- *Attractive
- *Animated
- *Use of media and technology

Neatness:

- *Balanced
- *Legible
- *Attractive
- *Colors Coordinate

Educational Value:

- *Promotes FCCLA
- *Provides information to the public

Relationship to State or National Programs:

*Use of current state or national programs evident.

Chapters may choose whether to spotlight one state and/or national program or to showcase more than one or all of the programs. Judges are instructed not to penalize chapters for limiting the booth to one or a few of the programs and not to award additional points for showcasing many programs.

State Programs:

- ___ Adopt-A-Chapter
- ___ Chapter Contributions
- ___ Georgia FFA-FCCLA Center Programs
- ___ Legislative Connection
- ___ Say Yes to FCS

National Programs:

- ___ Alumni and Associates
- ___ Career Connection
- ___ Community Service
- ___ FACTS
- ___ Financial Fitness
- ___ Families First
- ___ Japanese Exchange Program
- ___ Power of One
- ___ STAR Events
- ___ Stand Up
- ___ Student Body

Don't miss the FCCLA Leadership Rally at the Georgia National Fair!

**Wednesday, October 11, 2023, in Reaves Arena.
All affiliated members and chapters are invited to participate.**

**Check-in begins - 8:30 AM
Leadership Rally begins - 10:30 AM**

**See www.gafccla.com
for complete details!**

Recipe Format Tips

- Type or print legibly. Winning recipes may be used in a future edition of the Georgia National Fair Blue Ribbon Cookbook.
- List all ingredients in order of use in ingredients list.
- Include container sizes, for example, 16 oz. pkg. or 20 oz. can.
- Use standard abbreviations for measurements.
- Keep directions in paragraph form - not in numbered steps.
- Use names of ingredients in the directions, for example, "Combine flour and sugar." DO NOT use statements like "Combine first three ingredients."
- Include temperatures and cooking, chilling, baking, and/or freezing times.

Examples of standard abbreviations:

pt. = pint

qt. = quart

pkg. = package

env. = envelope

c. = cup

ctn. = carton

tsp. = teaspoon

T. = tablespoon

oz. = ounce

lb. = pound

gal. = gallon

doz. = dozen

sm. = small

md. = medium

lg. = large

Recipe Example:**My Favorite Apple Crisp**

4 cups apples, cored and sliced

1/2 tsp cinnamon

1 Tbsp water

1 cup sugar

3/4 cups all purpose flour

1/8 tsp salt

1/2 cup (one stick) of cold butter

Preheat oven to 375 degrees. Place sliced apples in 9x13 baking pan. Add cinnamon and water and stir to combine. In a medium bowl, add sugar, flour, and salt. Cut butter into small pieces. Mix into flour mixture with a fork or pastry blender until combined. Mixture should resemble coarse crumbs. Sprinkle dry mixture over apples. Bake about 1 hour, or until apples are tender.

FCCLA CHILI COOK-OFF COMPETITION

Coordinator Caitlin Roberson
770-530-1874 • croberson@gafccla.com

ALL EVENTS MUST BE ENTERED with the School Name in the “First Name” field and “FCCLA” in the “Last Name” field. (Example: First Name “Best High School” and Last Name “FCCLA”) and individual names must be listed in the Student Name field.

Enter online at GeorgiaNationalFair.com
(<https://www.georgianationalfair.com/p/georgialiving/youth>) **by September 20, 2023.**

WHEN: Tuesday, October 10

DIVISION 20403 FCCLA CHILI COOK-OFF MIDDLE SCHOOL (GRADES 6-8)

CHECK-IN AND SETUP: 1:00 PM; *Contest begins:* 1:30 PM

WHERE: Miller-Murphy-Howard Building Flower Show Area (North end of building)

DIVISION 20404 FCCLA CHILI COOK-OFF HIGH SCHOOL (GRADES 9-12)

CHECK-IN AND SETUP: 3:00 PM; *Contest begins:* 3:30 PM

WHERE: Miller-Murphy-Howard Building Flower Show Area (North end of building)

CLASS

01 FCCLA Chili Cook-off Competition

<u>1st</u>	<u>2nd</u>	<u>3rd</u>	<u>4th</u>
\$100	\$75	\$50	\$25

A copy of the online registration confirmation will be required to check-in for competition.

CONTEST RULES:

- ALL EXHIBITORS ARE REQUIRED TO READ AND ABIDE BY THE GEORGIA NATIONAL FAIR GENERAL RULES AND REGULATIONS. PLEASE NOTE: IT IS YOUR RESPONSIBILITY TO READ AND UNDERSTAND THE RULES. IF YOU HAVE QUESTIONS, YOU MAY CERTAINLY EMAIL US AT: contests@gnfa.com. PLEASE HELP US PREVENT ENTRY DISQUALIFICATIONS.**
- This Chili Cook-Off Competition will be an individual event. Only one entry per school will be allowed.
- The competition will be limited to 20 participants in each Section and, if need be, a lottery drawing will decide the 20 competitors.
- Each participant must be an affiliated FCCLA member.
- Each participant must supply their own Chili ingredients and cooking equipment (single gas burner).
- All preparation of Chili must be done on site, and from scratch – using raw meats and regular spices – no Chili mixes.
- Each participant will be judged on the following criteria:
 - Clothing & Appearance
 - Safety & Sanitation
 - Food Handling & Preparation Temperatures
 - Equipment & Tools
 - Presentation & Appearance
 - Taste
- Rubrics will be available to view in person post competition. Rubrics will not be released electronically.

TEAM COMPOSITION:

Individual; one person per team, will represent each school, supported by a teacher to help with moving equipment. The competitor will be responsible for all set-ups, production and presentation of food to judges and clean up.

FOOD REQUIREMENTS:

1. No restriction is placed on item usage. All ingredients used in the recipe must be from approved sources and maintained in accordance with approved Food Safety guidelines.
2. No pre-prepared foods are allowed – with the exception of canned tomatoes and canned beans only.
3. No pre-prepared sauce mixes or pre-mixed powders.
4. Competitors must maximize the use of fresh ingredients in the recipe.
5. No pre-cut items are allowed. All production must be on-site. Measuring must be done on-site.
6. Each participant must bring 3 printed copies of recipe to be used in a protective sheet **3** using the recipe format provided on page 11. A form is provided on page 12.
7. No alcohol can be used in the preparation of the chili.
8. All ingredients must be clearly labeled.

CHILI COMPETITION WILL CONSIST OF ONE PHASE:

1. Teams will be given 15 minutes to set up once all teams have checked in.
2. Teams will have staggered start times, dependent on the number of teams participating.
3. 1 hour for preparation and cooking.
4. 2 identical, no larger than 4” round bowls for judges; one for taste and one for show.

NO PLATES OR OTHER ACCESSORIES MAY BE BROUGHT TO THE JUDGES/SHOW TABLE.

5. **PLEASE BRING A TRAY TO DELIVER THE BOWLS TO THE JUDGES.**
6. 5 Points will be deducted for bowls that are larger than 4” in diameter.
7. When time is called, 2 identical bowls of Chili must be taken to the judges.

EQUIPMENT:

1. Teams must bring in all equipment and food that is needed to execute the Chili including a one burner butane gas burner (camping style).
2. Teams must only expect the organizer to provide an 8 foot by 2 foot table to work from, ice and potable water.
3. There is no power available for blenders, etc.

DRESS CODE:

1. Jeans and white T-shirt (or FCCLA T-shirt)
2. Closed-toe, non-slip shoes
3. Apron, gloves, protective head gear (hat, hair net, etc.)
4. School names and/or student names must be taped over.

JUDGES WILL LOOK AT THE FOLLOWING:

1. Sanitation; cold food cold and hot food hot.
2. Use of sanitation techniques for cleaning, food storage and potential cross contamination.
3. Use of tasting spoons by competitor.
4. Workspace and time management.
5. Realistic use of ingredients, equipment and work environment.
6. **Taste:** Complimenting use of spices, tenderness of protein, appropriate use of spice heat and developed full flavor.
7. **Texture:** Protein is tender, vegetable not mushy or raw, sauce not too thin or too thick and knife cuts uniform and appropriate to overall texture and ease of eating.
8. **Color:** Must be bright, fresh and appealing. Not dull or faded.
9. **Seasoning:** Use of salt and pepper to compliment and balance use of spices. No excessively hot peppers to be used.

CLEAN UP:

Students are also judged on final clean up.

ADVISORS/TEAM MANAGERS:

Once the competition begins, teachers/parents, etc., are unable to counsel students, and if they are found to be coaching students, the teacher/parent, etc., will be asked to leave the viewing area, and/or viewing area will be cleared.

FCCLA ANNUAL GEORGIA PEANUT RECIPE CONTEST

Coordinator Caitlin Roberson
770-530-1874 • croberson@gafccla.com

ALL EVENTS MUST BE ENTERED with the School Name in the “First Name” field and “FCCLA” in the “Last Name” field. (Example: First Name “Best High School” and Last Name “FCCLA”) and individual names must be listed in the Student Name field.

Sponsored by:



Georgia
Peanut
Commission

&



Enter online at GeorgiaNationalFair.com

(<https://www.georgianationalfair.com/p/georgialiving/youth>) by **September 20, 2023.**

WHEN: Wednesday, October 11

CHECK-IN AND SETUP: 10:15-10:45 AM; *Judging begins:* 11:15 AM

WHERE: Heritage Hall Kitchen

DIVISION 20501 - FCCLA GEORGIA PEANUT RECIPE CONTEST

CLASS

- 01 FCCLA GEORGIA PEANUT LEVEL 1 (GRADES 6-8)
- 02 FCCLA GEORGIA PEANUT LEVEL 2 (GRADES 9-10)
- 03 FCCLA GEORGIA PEANUT LEVEL 3 (GRADES 11-12)

<u>1st</u>	<u>2nd</u>	<u>3rd</u>	<u>4th</u>
\$100	\$75	\$50	\$25

A copy of the online registration confirmation will be required to check-in for competition.

CONTEST RULES:

- ALL EXHIBITORS ARE REQUIRED TO READ AND ABIDE BY THE GEORGIA NATIONAL FAIR GENERAL RULES AND REGULATIONS. PLEASE NOTE: IT IS YOUR RESPONSIBILITY TO READ AND UNDERSTAND THE RULES. IF YOU HAVE QUESTIONS, YOU MAY CERTAINLY EMAIL US AT: contests@gnfa.com. PLEASE HELP US PREVENT ENTRY DISQUALIFICATIONS.**
- Only one entry per school will be allowed. High schools may only choose level 2 or level 3. They may not have competitors in both levels.
- Competition will be limited to 20 participants per Division and, **if need be, a lottery drawing will decide the 20 competitors.**
- Each participant must be an affiliated FCCLA member.
- Each participant will CREATE an original recipe using peanuts, peanut butter, or peanut flour/powder.
- Product type for 2023: Cookie**
- Each participant will bring at least 4 servings of the prepared recipe (2 cookies per serving) to the Heritage Hall Kitchen. One serving will remain on display at the fair.
- Each serving will need to be placed on a separate, identical, disposable plate, no larger than 6” in diameter, for judging. Decorative packaging does not meet these guidelines.
- All entries must be presented using proper sanitation techniques; for example, **plastic wrap covering the cookie.**

-
10. Each participant will submit 3 identical copies of the recipe (2 for FCCLA and 1 for GNF use), two on a 4x6 index card and one using the recipe provided on page 11. A form is provided on page 12. Please place the school and participant's names on the back of the recipe. No recipes will be returned. Do not provide additional information.
 11. Entries will be judged on sanitation; presentation and appearance; recipe and ingredient compatibility; flavor, taste, texture, and doneness; and originality.
 12. Pre-mixed items are not allowed (i.e., cookie or cake mixes).
 13. If your recipe has multiple components (i.e., item and frosting, etc.), you must provide complete recipes for all components.
 14. Winners will be announced when judging is complete, or at approximately 2:30 PM
 15. This event is sponsored by the Georgia Peanut Commission and Georgia FCCLA. Premium checks will be mailed from the Georgia FCCLA office.

FCCLA CULINARY COMPETITION

Coordinator Caitlin Roberson
770-530-1874 • croberson@gafccla.com

ALL EVENTS MUST BE ENTERED with the School Name in the “First Name” field and “FCCLA” in the “Last Name” field. Example: First Name “Best High School” and Last Name “FCCLA”) and individual names must be listed in the Student Name field.

Enter online at GeorgiaNationalFair.com
(<https://www.georgianationalfair.com/p/georgialiving/youth>) **by September 20, 2023.**

WHEN: Wednesday, October 11

CHECK-IN AND SETUP: 1:15 PM; *Contest begins:* 1:30 PM

WHERE: Miller-Murphy-Howard Building Flower Show Area (North end of building).

DIVISION 20601 - FCCLA CULINARY COMPETITION

CLASS

01 FCCLA Culinary Competition

<u>1st</u>	<u>2nd</u>	<u>3rd</u>	<u>4th</u>
\$100	\$75	\$50	\$25

A copy of the online registration confirmation will be required to check-in for competition.

CONTEST RULES:

- ALL EXHIBITORS ARE REQUIRED TO READ AND ABIDE BY THE GEORGIA NATIONAL FAIR GENERAL RULES AND REGULATIONS. PLEASE NOTE: IT IS YOUR RESPONSIBILITY TO READ AND UNDERSTAND THE RULES. IF YOU HAVE QUESTIONS, YOU MAY CERTAINLY EMAIL US AT: contests@gnfa.com. PLEASE HELP US PREVENT ENTRY DISQUALIFICATIONS.**
- This Culinary Competition will be an individual event. Only one entry per school will be allowed.
- The competition will be limited to 10 participants and, **if need be, a lottery drawing will decide the 10 competitors.**
- Each participant must be an affiliated FCCLA member who is currently taking or has previously taken a culinary arts course.
- Each participant will be judged and given 30 minutes on the following knife skills:
 - 2 oz. Julienne Carrot
 - 2 oz. Onion Dice
 - 1 Whole Tomato Concasse
 - 1 oz. Brunoise Carrot
- Each participant will be given one hour to prepare 2 identical “Hot Plated Meals”, each plate consisting of:
 - 1 Chicken Breast (FCCLA provides)
 - 1 Appropriate Starch
 - 1 Vegetable
- Each participant will bring:
 - Their own carrot, onion, and tomato to be used in the knife skills demonstration, in addition to their starch and vegetable to be used in their hot plate. Participants may use their knife cuts after they have been judged in their entrée preparation.
 - 2 identical plates for plating, no larger than 10” in diameter.
 - **3 copies of recipe in sheet protectors** using the recipe format provided on page 11. A form is provided on page 12.
- Each participant should bring temperature sensitive items on ice, as well as ice for their chicken. Ice will not be available on site.
- Each participant will be given ONE 8 foot table to work with, speed racks are acceptable to bring (preferably the

short ones) – and will be checked to verify no prep work has been done previously.

10. Once the competition begins, teachers/parents etc. are unable to counsel students, and if they are found to be coaching students, the teacher/parent etc. will be asked to leave the viewing area, and/or viewing area will be cleared.
Additions to Culinary Competition guidelines:

FOOD REQUIREMENTS:

1. No restriction is placed on food ingredients; students must bring all ingredients with them and held under correct sanitation food safety temperature guidelines.
2. No pre-prepared foods are allowed, with the exception of canned items.
3. No pre-prepared sauce mixes or pre-mixed powders are allowed.
4. All potentially hazardous foods must be kept chilled.
5. No alcohol can be used in the preparation of the dishes.
6. All ingredients must be clearly labeled.
7. All measuring must be done on-site.

EQUIPMENT REVIEW:

1. Students must bring in all equipment and food that is needed (except the chicken breast), including up to 2 butane gas burners
2. There will be no power available for blenders, etc.

DRESS CODE:

1. Closed-toe, non-skid shoes appropriate for kitchen
2. Appropriate chef attire (including chef jacket, apron, head covering, and pants/long skirt)

JUDGES WILL LOOK AT THE FOLLOWING:

1. Sanitation: cold food cold and hot food hot
2. Use of sanitation techniques for cleaning, food storage and potential cross contamination
3. Use of tasting spoons by competitor
4. Workspace and time management
5. Realistic use of ingredients, equipment and work environment
6. Station clean-up
7. Taste
8. Texture
9. Color
10. Seasoning
11. Adequate protein serving

COMPETITION REVIEW:

- 15 minute check-in (registration)
- 30 minutes on knife skills
- 15 minutes for mise en place
- 60 minutes to prepare 2 identical “hot plated meals”

CULINARY COMPETITION SUPPLY LIST:

- Carrot for knife skills
- Onion for knife skills
- Tomato for knife skills
- Short speed rack (optional)
- All other ingredients in meal (including 1 appropriate starch and 1 vegetable)
- 2 identical plates for plating
- 3 copies of recipe in sheet protectors (includes name of school and competitor on the back)
- 1-2 butane gas burners
- Ice for chicken and other temperature sensitive items

FCCLA INDIVIDUAL THEME SPEECH COMPETITION

Coordinator Caitlin Roberson
770-530-1874 • croberson@gafccla.com

ALL EVENTS MUST BE ENTERED with the School Name in the “First Name” field and “FCCLA” in the “Last Name” field. Example: First Name “Best High School” and Last Name “FCCLA”) and individual names must be listed in the Student Name field.

Enter online at www.GeorgiaNationalFair.com
(<https://www.georgianationalfair.com/p/georgialiving/youth>) **by September 20, 2023.**

WHEN: Wednesday, October 11

CHECK-IN AND SETUP: 1:00 PM; *Middle School Contest begins:* 1:30 PM ; *High School Contest begins:* Immediately following Middle School competition. Individual start times will be assigned at check-in.

WHERE: Heritage Hall Stage

DIVISION 20703 FCCLA INDIVIDUAL THEME SPEECH MIDDLE SCHOOL (GRADES 6-8)

DIVISION 20704 FCCLA INDIVIDUAL THEME SPEECH HIGH SCHOOL (GRADES 9-12)

CLASS

01 FCCLA Theme Speech Competition

<u>1st</u>	<u>2nd</u>	<u>3rd</u>	<u>4th</u>
\$100	\$75	\$50	\$25

A copy of the online registration confirmation will be required to check-in for competition.

CONTEST RULES:

1. **ALL EXHIBITORS ARE REQUIRED TO READ AND ABIDE BY THE GEORGIA NATIONAL FAIR GENERAL RULES AND REGULATIONS. PLEASE NOTE: IT IS YOUR RESPONSIBILITY TO READ AND UNDERSTAND THE RULES. IF YOU HAVE QUESTIONS, YOU MAY CERTAINLY EMAIL US AT: contests@gnfa.com. PLEASE HELP US PREVENT ENTRY DISQUALIFICATIONS.**
2. Entries are limited to one (1) individual student member per chapter.
3. Competition will be limited to 15 participants in each Division and, if need be, a lottery drawing will decide the 15 competitors.
3. Student's must prepare a speech on the current National Theme.
4. Order of the competition will be pre-assigned on a random selection basis.
5. Competitors may use 3"x5" index cards only for brief outline/key ideas. Any other material will not be allowed. At the time of the competition, competitors shall be introduced to the judges and will present his/her speech using no references other than his/her 3"x5" index card.
6. Props may not be used. If props are used, the competitor will be disqualified.
7. The speech shall be a maximum of three (3) minutes in length. The timekeeper shall give a 1-minute warning. The competitor will be stopped when the 3 minutes are up.
8. A microphone will be provided, and the competition is open to spectators.
9. Competitors must be dressed appropriately and professionally.
10. Speeches will be evaluated on:
 - Content (45 points)
 - Organization (30 points)
 - Delivery (25 points)
11. Winners will be announced after a brief intermission once competition is completed. All competitors are to report back to the stage for presentation.