

MANATEE COUNTY FAIR 2022
Horse

FAIR LIVESTOCK DIRECTOR: John Barnett
AREA SUPERINTENDENT: Karen Ciemniecki

Must Registration online from October 1st - October 18, 2021

All Exhibitor registrations must be complete by Monday, October 18, 2021

A complete registration includes the following:

- 1) MANDATORY Meeting for Horse Exhibitors and a Parent or Legal Guardian** - must come by Karen Ciemniecki's house (12700 Upper Manatee River Rd. Bradenton) between 3-6pm, Thursday, November, 30, 2021. You must have a completed and Notarized MRFA Exhibitor Liability/Photo Release. Make sure you bring the form with you and turn it in or you will be considered ineligible.
- 2) On-line registration** found at Manateecountyfair.com, (ShoWorks) complete by October 18, 2021

Failure to complete both will result in disqualification.

SCHEDULE

Mandatory Meeting	November 30, 2021 3-6pm Karen Ciemniecki's Home
On-line registration- Exhibitor Passes	completed notarized MRFA Exhibitor/Photo Release handed in
Fair Check in	October 1st - October 18, 2021
Fair Horse Show-	Purchase when registering your animal on line through ShoWorks
Livestock Judging	Sunday, January 2, 2022 10am Mosaic Arena
Livestock Judging	Sunday, January 2, 2022 12- 6pm Mosaic Arena
Awards Ceremony	Saturday, January 15 Registration 7:30am Start 8am Mosaic Arena
	Saturday, January 22 Registration 7:30am Start 8am Mosaic Arena
	Saturday, January 22, 2022 7pm Mosaic Arena

HORSE

Rules and Regulations

1. All exhibitors must be a *bona fide* member of a Manatee County 4-H Club or FFA Chapter, which is related to your project. No one who has graduated from High School will be eligible to show. All 4-H and FFA Exhibitors must attend a Manatee County Public School or reside in Manatee County. Home Schooled Exhibitors must live in Manatee County. **All Exhibitors at the Manatee County Fair must have completed one class of ethics training before being allowed to show. There will be an Ethics Training Class administered on October 30th at the Manatee County Fairgrounds. Exhibitors will be required to sign up for the class at the following site when it is available.** <https://floridastatefair.com/ag/exhibitor-ethics/>
2. No exhibition of horses by anyone less than 8 years of age (as of September 1, 2021) will be allowed.
3. At Final Fair check-in, Exhibitor and animal must be together in order for animal to be checked in. A parent or legal guardian must complete all required documentation. The Manatee River Fair Board encourages parents to be involved in their child's 4-H and FFA Projects.
Exhibitors are not allowed to change animal exhibits after the initial check-in
4. **Mandatory Meeting** all Horse Exhibitors; and a Parent or Legal Guardian must come by Karen Ciemniecki's house (12700 Upper Manatee River Rd. Bradenton) between 3-6pm, Thursday, November 30, 2021. **You must have a completed and** notarized MRFA Exhibitor Liability/Photo Release. Make sure you bring the Notarized form with you and turn it in or you will be considered ineligible.
5. All exhibitors must be in good standing with their respective clubs to exhibit at the Manatee County Fair. All exhibitors will show in the 4-H Club or FFA Chapter in which they registered their livestock at their respective check-in event.
6. Each exhibitor assumes all liability in case of death or injury to his/her animal.
7. All Exhibitors must wear boots (must be above the ankle height) when on or handling hoofed animals on Fairgrounds property, including from the initial check-in forward.
8. All record books must be up to date and checked in to the designated committee at time of final check-in at the Fair. An up-to-date record book is required for ALL Horses that were registered at the initial check-in, whether that animal made it to the fair or not. **If your horse didn't make the final check-in, your record book is still required to be e-mailed to ManateeCountyHorse@manateecountyfair.com by the end of the fair, in order to be eligible to show the next year in the Manatee County Fair.** A committee appointed by the Livestock

Committee will check record books at final check in. EACH exhibitor showing a club or chapter animal must submit a care and feed guide, even if the animal is shared by several exhibitors.

9. Use of drugs not in compliance with manufacturer's label as to method of use, dosage, time limitations and show regulations is prohibited. The use of any calming agents on animals during the Fair or the possession of same by a 4-H or FFA member or anyone assisting said member with his or her animal is prohibited. Violation of this provision shall disqualify the animal from competition and any awards or premiums, including sale price of animal, shall be forfeited. If medical treatment is deemed necessary, the exhibitor or parent must notify the Area Livestock Director and/or Barn Superintendent, prior to administering treatment to the animal in any way.
10. All animals are subject to being examined and urine and blood tested for any drug usage at any time. Refusal by the 4-H or FFA member to submit their animal to such examination or test will result in immediate disqualification and forfeiture of all premiums and awards.
11. Upon disqualification, pursuant to Paragraphs No.9 and 10 the affected animal shall immediately be removed from the Fairgrounds.
12. On-site inspections of any livestock may be made by authorized agents of the Manatee River Fair Association at any time, after first check-in or before Fair.
13. All livestock must follow Florida Department of Agriculture and Consumer Services State Health Guidelines and be transported to the Manatee County Fair in accordance with those guidelines.
14. ***Final Interpretation of these rules will be vested in the Manatee River Fair Board Livestock Committee.***

HORSE RULES AND REGULATIONS

All General Livestock Rules apply to this specific area.

Examples of a pattern will be posted the day of show, unless pre-released by the judge.

CLASSES:

1. Grade Mares
2. Grade Geldings
3. Registered Mares
4. Registered Geldings
5. Junior Western or English Showmanship
6. Senior Western or English Showmanship
7. Walk Trot English or Western Pleasure (cannot enter a canter/lope class)
8. Walk Trot Equitation (cannot enter a canter/lope class)
9. Junior English Pleasure
10. Senior English Pleasure

11. Junior English Equitation
12. Senior English Equitation
13. Junior Western Pleasure
14. Senior Western Pleasure
15. Junior Western Equitation
16. Senior Western Equitation
17. Jr. Ranch Riding
18. Sr. Ranch Riding
19. Junior Poles
20. Senior Poles
21. Stake Race
22. Junior Barrels
23. Senior Barrels
24. Keyhole

- Juniors are 12 years or under as of Jan. 1, 2022. Seniors are 13 or over as of Jan. 1, 2022.
- Must be a member of Manatee County 4-H or FFA, within the ages of 8-18, and show a current record book at time of check-in.
- Current Coggins will be checked at gate before horse will be allowed on grounds.

ALL CLASSES

- Personal appearance of club member: All exhibitors are required to wear a SEI or ASTM approved equestrian safety helmet with chin strap fastened and their number clearly displayed. Western and Ranch Classes- long sleeved shirt, tie or scarf optional, jeans or pants and western boots; if showing FFA, official dress may be worn. English classes- hunt or saddle coat, shirt with stock collar or tie, paddock or English boots, and breeches or jodhpurs pants. Gloves are optional.
- A judge or show official shall have the authority to require the removal or adjustment of any piece of equipment which in his/her opinion is unsafe, or constitute excessive harshness or cruelty.
- A judge or show official shall have the authority to dismiss any exhibitor for:
 - excessive harshness or cruel handling of a contestant horse
 - Excessive poor body condition of any contestant horse, less than 4 based on the Henneke scale (ribs easily discernible, tops of spinous process easily discernible, tailhead prominent with hook bones easily discernible, withers accentuated, and neck obviously thin).
 - Obvious or excessive lameness or physical injury of any contestant horse.

CLASSES #1-4 CONFORMATION

1. Personal appearance of club member: neat, clean, courteous and in appropriate attire. If showing in FFA official dress must be worn except for in certain classes.
2. Horses are judged on conformation, condition, soundness, and way of going.

3. Horses will be judged individually while standing, at a walk and a trot.
4. Horse may be shown in halters made of leather, rope, or other suitable material. English may be shown in bridle.
5. Whips or bats are not permitted in halter classes.
6. Horses will be handled and shown by one club member only.
7. Horses enter ring as instructed by Judge or ring steward.

CLASSES #5-6 SHOWMANSHIP

- Showmanship classes are not conformation, model or grooming classes. This is a performance class with emphasis to be placed on the exhibitor's ability to show their animal.
- English equipment: Clean, adjusted and acceptable bridle or leather halter.
- Western Equipment: Clean, adjusted halter to fit horse. Fancy halters shall not be given preference over good working halters.
- Horse shall be clean, well groomed and fitted for its type. The feet should be clean or properly shod.
 - Class Procedures: Each exhibitor will individually perform a given pattern which will be composed from the following optional list of tests. The judge will score each exhibitor on his/her individual skills and execution of the pattern. Optional list of tests for exhibitors which may be executed collectively or individually follows (Junior division entrants may be tested using 1-8; Senior division entrants may be tested using 1-11):
 - (1) Square horse for inspection: Judge may walk completely around horse as exhibitor demonstrates the quarters system.
 - (2) Walk a straight line or walk a curve*, either direction
 - (3) Trot (or natural gait) a straight line
 - (4) Trot (or natural gait) a curve*, either direction
 - (5) Pivots, moving the forehand up to 360°
 - (6) Stop
 - (7) Back straight
 - (8) Answer questions from the judge
 - (9) SR only – Back a curve*
 - (10) SR only – Extension of walk or trot.
 - (11) SR only – Western Showmanship only: pivots up to 540° (1½ turns)
- Faults at showing at showmanship:
 - a) Allowing the horse to remain out of position.
 - b) Standing directly in front of your horse.
 - c) Kicking horse's feet to move them.
 - d) Failure of the horse to lead properly.
 - e) Failure to back
 - f) Loud voice commands or other unnecessary actions
 - g) Picking up the horse's feet for positioning purposes.

*** GENERAL RULES FOR ENGLISH-CLASSES #7-8 & 9-12**

Tack: Clean English type hunt, jump or flat saddles. Snaffle, Pelham, Kimberwick, or Weymouth bit is permitted. A Cavesson noseband is required. Pelham bridles must have two sets of reins attached. Pelham connectors not allowed. Breast plates are optional. Martingales are not allowed. Draw reins and hackamore are not permitted. No figure 8 or drop nose bands allowed. English spurs and crops/bats are optional. Two hands to be used on reins.

CLASSES #7-8 WALK TROT

1. Exhibitor may show western or English appropriate attire and tack outlined in division rules.
2. Horses are shown on the rail at a walk, jog or trot or natural gait while maintaining light contact of mouth.
3. Horses must work both directions on the rail.
4. Horses should back easily and stand quietly.
5. Class #7-Pleasure This class will be judged on the horse's way of going, manners and suitability.
6. Class #8-Equitation class will be judged mostly on the rider's performance.
7. Cantering and loping are not allowed in these classes, or other classes at this show this day.
Classes #7-8 are for exhibitors with limited show experience who have not loped or cantered at shows.

CLASS # 9 Junior English Pleasure

CLASS #10 Senior English Pleasure

1. The class will be judged on the horse's way of going, manners and suitability.
2. Horses are shown on the flat at a walk, trot or natural gait, & canter while maintaining light contact of mouth.
3. Horses must work both directions on the rail.
4. Horses should back easily and stand quietly.

CLASS #11 Junior English Equitation and #12 Senior English Equitation

1. The rider's performance and skills are being judged in this class.
2. Each rider will be asked to perform a pattern. Following pattern, rail work may be required.
3. The judge will score the rider's skills and execution of the pattern and rail work.
4. Horses will be shown at the walk, posting trot, and canter
5. Optional list of tests for exhibitors which may be executed collectively or individually follows (Junior division riders may be tested using 1 through 5; Senior division riders may be tested using 1 through 10):
6. (Optional list of tests:
 - (1) Perform gaits in straight lines, curves, circles, or any combination to create additional shapes.
 - (2) Back

- (3) Halt from a canter
- (4) Figure 8 with proper change of diagonals
- (5) Figure 8 at canter on correct leads with simple change of leads (flying lead change may be required for SR)
- (6) Walk from a gallop with emphasis on hands SR only
- (7) Counter Canter for SR only
- (8) Demonstrate a turn on forehand or haunches SR only
- (9) Ride without stirrups SR only
- (10) Execute a slow sitting trot, posting trot or extended trot SR Only

CLASSES #7-8 & 13-18 GENERAL RULES FOR WESTERN AND RANCH

Personal: Western spurs, chaps, and gloves are optional.

Tack: Horses shall be shown with a western saddle, silver will not count extra. Martingales, tie-downs, nose bands or draw reins are prohibited.

- Horses 5 years of age or younger may be shown with two hands on the reins and a smooth snaffle bit or bosal. Reference to snaffle bits mean the conventional O-ring, egg-butt, or D-ring with ring no larger than 4". The mouthpiece should be round, oval, or egg-shaped, smooth and unwrapped metal. It may be inlaid, but must be smooth. The bars must be a minimum of 5/16" in diameter, measured one inch in from the cheek with a gradual decrease to center of the snaffle. The mouthpiece may be two or three pieces. A three-piece connecting ring of 1¼" or less in diameter, or a connecting flat bar of 3/8" to 3/4" (measured top to bottom), which lies flat in the horses mouth, or rollers are acceptable. References to bosal mean the use of a non-mechanical flexible, braided rawhide or leather, or rope bosal, the core of which may be either rawhide or flexible cable. Absolutely no rigid material will be permitted under the jaws, regardless of how padded or covered. Leather or woven split reins are acceptable with a snaffle bit, and leather or woven split reins, or mecate reins are acceptable with bosal. Reins to be held in two hands with "bridge" between hands.
- All age horses may be shown, and all horses age 6 and over must be shown in a curb bit that has a solid or broken mouthpiece, has shanks, and acts with leverage. Leather split reins must be used. Only one hand may be used on the reins, hand must not be changed, hand is to be around the reins, and if desired only the index finger may be between the reins. Violation of this rule is an automatic disqualification. All curb bits must be free of mechanical device and should be considered a standard western bit. A description of a legal, standard western bit includes:
 - 8½" maximum length shank. Shanks may be fixed or loose.
 - Curb bit mouthpieces must be round, smooth, and unwrapped metal of 5/16" to 3/4" in diameter, measured one inch in from the cheek. They may be inlaid, but must be smooth.
 - Nothing may protrude below the mouthpiece (bar), such as extensions or prongs on solid mouthpieces. The mouthpiece may be two or three pieces.
 - The port must be no higher than 3½" maximum, with rollers and covers acceptable. B

- A curb bit must be used with a curb strap or curb chain properly attached so as to make contact with horses chin. Chain curb straps must be at least 1/2" in width, and lie flat against the jaw of the horse. No wire curbs, regardless of how taped or padded. Absolutely no rigid material will be permitted under the jaws, regardless of how padded or covered.
- A romal rein is acceptable. A romal means an extension of braided material attached to closed reins. This extension may be carried in the free hand with an approximate 16" spacing between the reining hand and the free hand holding the romal. The rider's hand shall be around the reins with the fingers closed, thumb on top, and no fingers between the reins. The romal shall not be used forward of the cinch; or to signal or cue the horse in any way. Any infraction of this rule shall be penalized severely by the judge.

CLASSES #13-14 WESTERN PLEASURE

1. Horse to be shown at walk, jog and lope on a loose rein or light contact
2. Horses must work both directions on the rail, back easily and stand quietly.
3. Horses are asked to be reversed to the inside (away from the rail)
4. This class will be judged on the performance of the horse. The class will be judged on the horse's way of going, manners and suitability.

CLASSES #15 Junior Western Equitation

CLASSES #16 Senior Western Equitation

1. This class will be judged on the performance of the rider.
2. Each rider will be asked to perform a pattern. Following pattern, rail work may be required.
3. The judge will score the rider's skills and execution of the pattern and rail work.
4. Horse to be shown at walk, jog and lope on a loose rein or light contact
5. Optional list of tests for exhibitors which may be executed collectively or individually follows (Junior division riders may be tested using 1 through 6 Senior division riders may be tested using 1 through 11:
 - (1) Perform gaits in straight lines, curves, circles, or any combination to create additional shapes.
 - (2) Stop.
 - (3) Back.
 - (4) Pivot, both ways of varying degrees: 90, 180, 270, 360, etc.
 - (5) Pickup leads from standstill, walk, or jog.
 - (6) Simple lead changes in a circle or on a straight away.
 - (7) *SR only*- Side pass.
 - (8) *SR only*- Rollbacks.
 - (9) *SR only*- Extended gaits.
 - (10) *SR only* – Flying lead changes.
 - (11) *SR only* – Counter canter.

CLASSES #17-18 RANCH RIDING

Tack: See **General rules for Western Classes 13-18, modified below.** Ranch work equipment is recommended, but show equipment will not be penalized. Roping reins or reins with romal are permitted, as long as they are not used to strike a horse. Martingales, tie-downs, nose bands, or draw reins are prohibited. In ranch classes when showing in a curb bit, reins must be held in one hand, but may be held in any manner. Hoof polish, braided or banded manes, tail extensions, and trimming inside ears are strongly discouraged.

Ranch riding serves to measure the ability of the horse to be functional and a pleasure to ride at a working speed while being used as a means of conveyance from one western stock horse task to another. The horse's performance should simulate a horse riding outside the confines of an arena and that of a working ranch horse. This horse should be well-broke, relaxed, quiet, soft, and cadenced at all gaits. The horse should be responsive to the rider, yield to contact, and make all required transitions smoothly, timely and correctly. The horse should perform with reasonable speed, and be obedient, well-mannered, free, and easy moving.

Class consists of pattern work which is ridden individually. For each maneuver, the horse is judged on quality of gaits, response to the rider, manners, and disposition. Maneuvers may include:

- A. Walk, trot, and lope both directions.
- B. Extended trot and extended lope at least one direction.
- C. Stop and back from any gait.
- D. Side pass.
- E. Turns on the hindquarters of up to 2½ turns.
- F. Turns on the forehand of up to 180°.
- G. Change of lead (simple or flying).
- H. Walk, trot, or lope over a pole(s).
- I. Work hard gate.

***SPEED-CLASSES #20-25**

Tack: Western type saddles. Hackamore may be used. Two hands on reins are allowed in speed. Use of martingale, tie-downs and nosebands is permitted. Draw reins are not allowed. Bandages (leg wraps) are not allowed. Protective leg boots (sports medicine boot type) are allowed.

1. These contests are timed. Timing shall begin as soon as the horse's nose crosses the start line and will be stopped when the horse's nose crosses the finish line.
2. Horse must be under the control of the rider upon entrance and exit of arena. No horse or rider will be assisted inside the arena.
3. Times will be available upon request.
4. No string or rubber bands or other material to tie feet or legs in stirrups is allowed. The use of any material to affix rider to any part of the saddle is prohibited.
5. Failure to follow or complete pattern is disqualification.
6. Touching poles or barrels with hands is disqualification. Hands should stay on reins.

7. Striking a horse in front of the cinch with anything other than the open hand is a disqualification. Striking in front of the throatlatch is a disqualification.

CLASSES #19-20 POLE BENDING

1. The Pole pattern is to be run around six poles. Each pole is to be 21 feet apart.
2. Horse may start at the left or right and then run the pattern accordingly.
3. Knocking over a pole is a 5 second penalty.

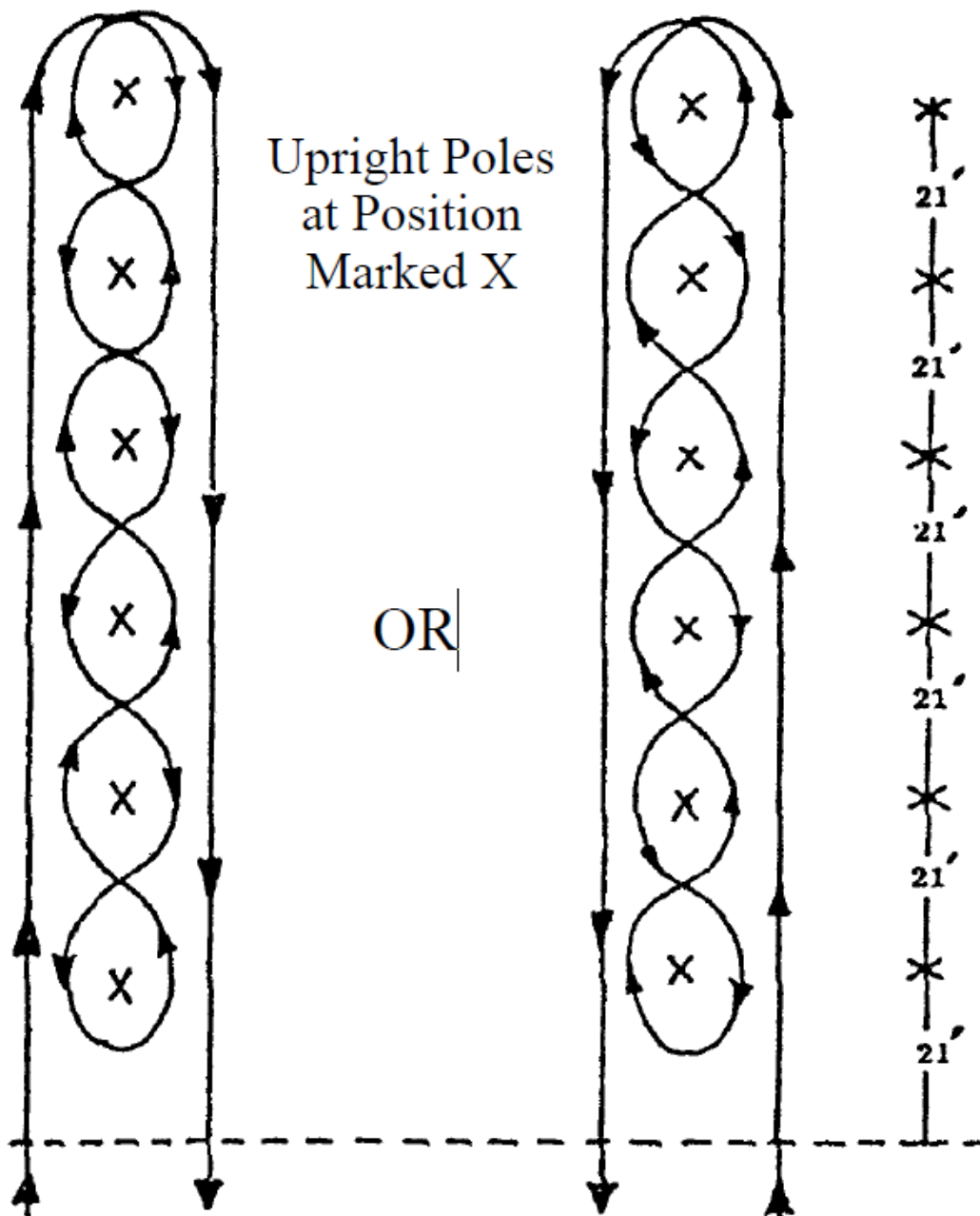

CLASS #21 STAKE RACE

1. Start by crossing start line between start/finish markers. Contestant may or may not cross center line (dotted) in going to first end pole. At the first pole, contestant may go right or left. Between first turn and second turn horse must cross center line (dotted). The second turn **MUST** be opposite the first turn. Finish by crossing or not crossing center (dotted) line between start/finish markers.
2. Upright end poles are set 40 feet on each side of the start/finish line. Two upright markers will be placed on the start/finish line (10 feet on each side of the dotted center line). If an electric timer is used, it is suggested that rubber cones, short enough so as not to interfere with the timer, be used.
3. Failure of contestant to cross start/finish line between markers will result in disqualification.
4. Knocking over pole or any start/finish marker constitutes a five (5) second penalty.

ACCEPTABLE STAKE RACE PATTERNS

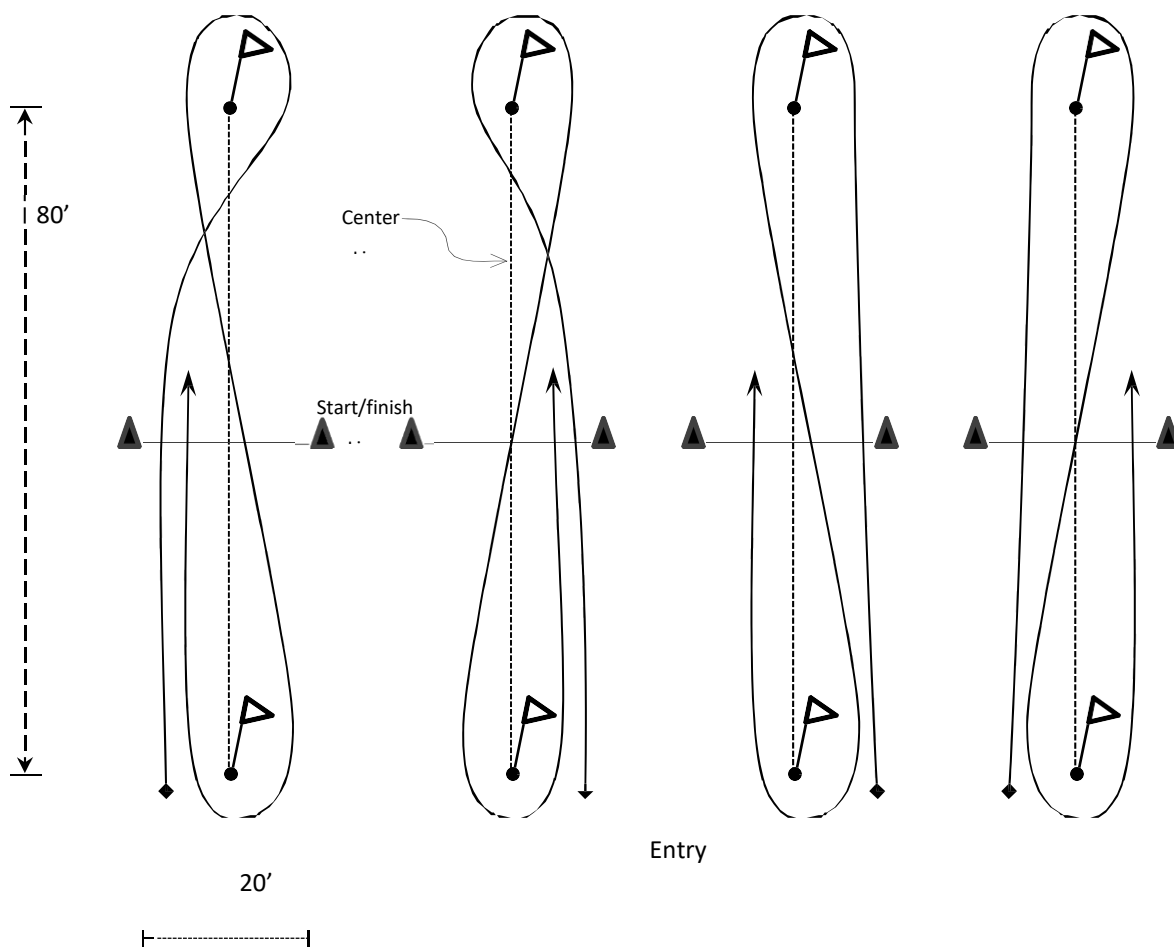

Pattern may be run from either right or left, at discretion of contestant.

CLASS #22 Junior BARRELS

CLASS #23 Senior BARRELS

- First and second barrel should be at least 20 feet from fence.
- The contestant will run to barrel number 1, pass to the left of it, and complete a slightly more than 180 degree turn around it; then go to barrel number 2, pass to the right of it, and complete a slightly more than 180 degree turn around it; then go to barrel 3, pass to the right of it, and turn approximately 180 degrees around it; and then sprint to the finish line passing between barrels 1 and 2.
- This barrel course may also be run to the left. For example, the contestant will start to barrel number 2, turning to the left around this barrel, then to barrel number 1, turning to the right, then to barrel number 3, turning to the right, followed by the final sprint to the finish line.
- Each barrel knocked over shall carry a five (5) second penalty
5. Off course shall be a disqualification.

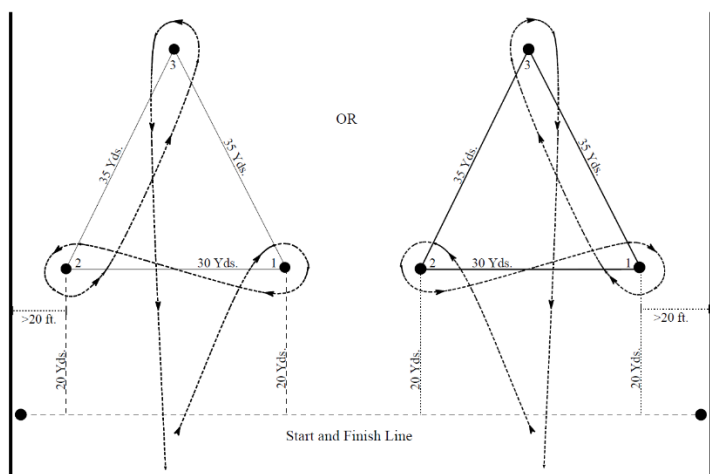

CLASS #24 KEYHOLE

- Time starts as the contestant crosses the start-finish line, and enters the five foot entrance, turn right or left in the circle, return through entrance and cross the finish line, must stay inside markers, time ends at finish line.
- Starting line shall be 40-100 feet from the keyhole entrance.
- Entrance shall be 5 feet wide by 10 feet long, connected to a 20 foot circle.
- A contestant is disqualified if a horse steps on or outside the markings of the circle, or fails to cross the finish line inside the markers.
5. Flour is suggested to lay out the patterns.

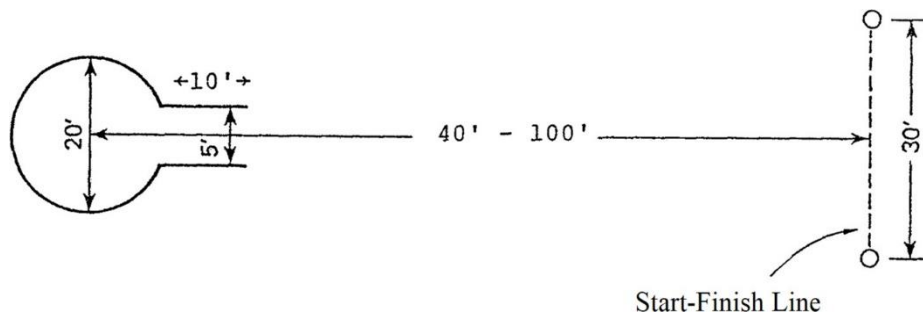

Exhibitor and Parent Security Passes

Exhibitors can make a one-time purchase of a \$25 Security Entrance Pass that will give unlimited access to the fair for the entire run of the Fair. Families will be allowed to purchase (4) additional Security Entrance Passes at \$25 each which also gives unlimited access to the fair.

**Passes need to be purchased when you register your animal on line through ShoWorks
Last day to purchase passes is October 23, 2021.**

If not purchased by October 23, 2021 the cost will be \$30 each with same limits as above.
****THERE WILL BE NO REFUNDS ON PASSES****

Manatee County Fair Web-Site

The Manatee County Fair has its own web page!! Rule books and Record Books are posted and may be printed from www.manateecountyfair.com. Please check the web page periodically to see if there are any updates that pertain to your livestock area. Registration paperwork for all animal areas is located on the Fair web-site. Examples of a pattern will be posted the day of show, unless pre-released by the judge

QUESTIONS

If you have a question about your entry into the Manatee County Fair, please follow the chain-of-command as listed below:

1st – Contact your **CLUB LEADER**; if they are unable to answer your question, then

2nd -Contact **AREA SUPERINTENDENT** – Horses, Karen Ciemniecki 941-725-0603

3rd -Contact the **FAIR LIVESTOCK DIRECTOR** – Horses, John Barnott – 941 722-1639