

Pattern Book

Tulsa State Fair
Junior and Open Horse Show

2023
Tulsa, OK

Western Horsemanship

Walk/Trot

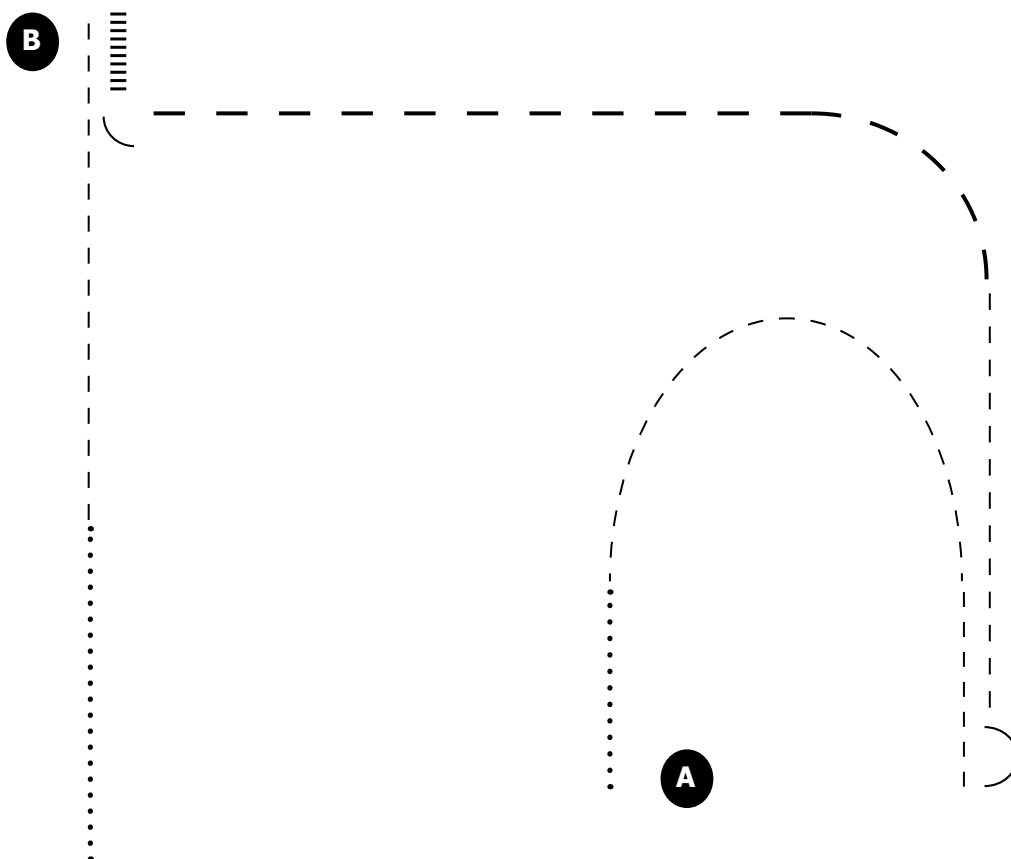

1. Walk.
2. Jog.
3. Stop. Execute $\frac{1}{2}$ turn left on the haunches.
4. Jog.
5. Extended jog.
6. Stop. Execute $\frac{1}{4}$ turn left on the haunches. Back.
7. Jog.
8. Walk to exit.

Walk
Jog	-----
Ext. Jog	—— —
Lope	————
Back	

Western Horsemanship

All classes except Walk/Trot

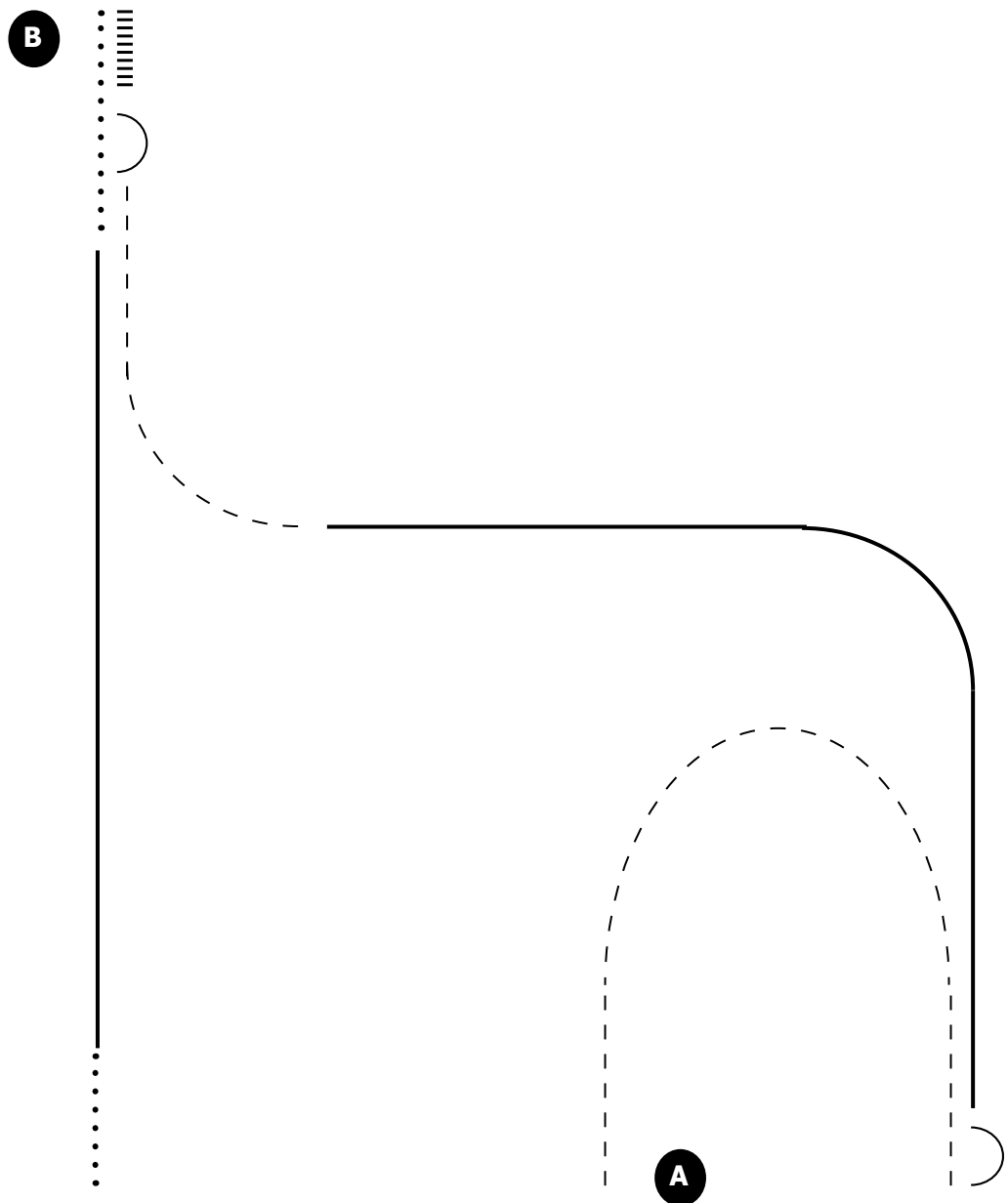

Walk
Jog	-----
Ext. Jog	- - - -
Lope	————
Back	

1. Jog.
2. Stop. Execute $\frac{1}{2}$ turn left on the haunches.
3. Lope, left lead.
4. Jog.
5. Stop. Execute $\frac{1}{2}$ turn right on the haunches. Back.
6. Walk.
7. Lope, right lead.
8. Walk to exit.

Hunt Seat Equitation

Walk/Trot

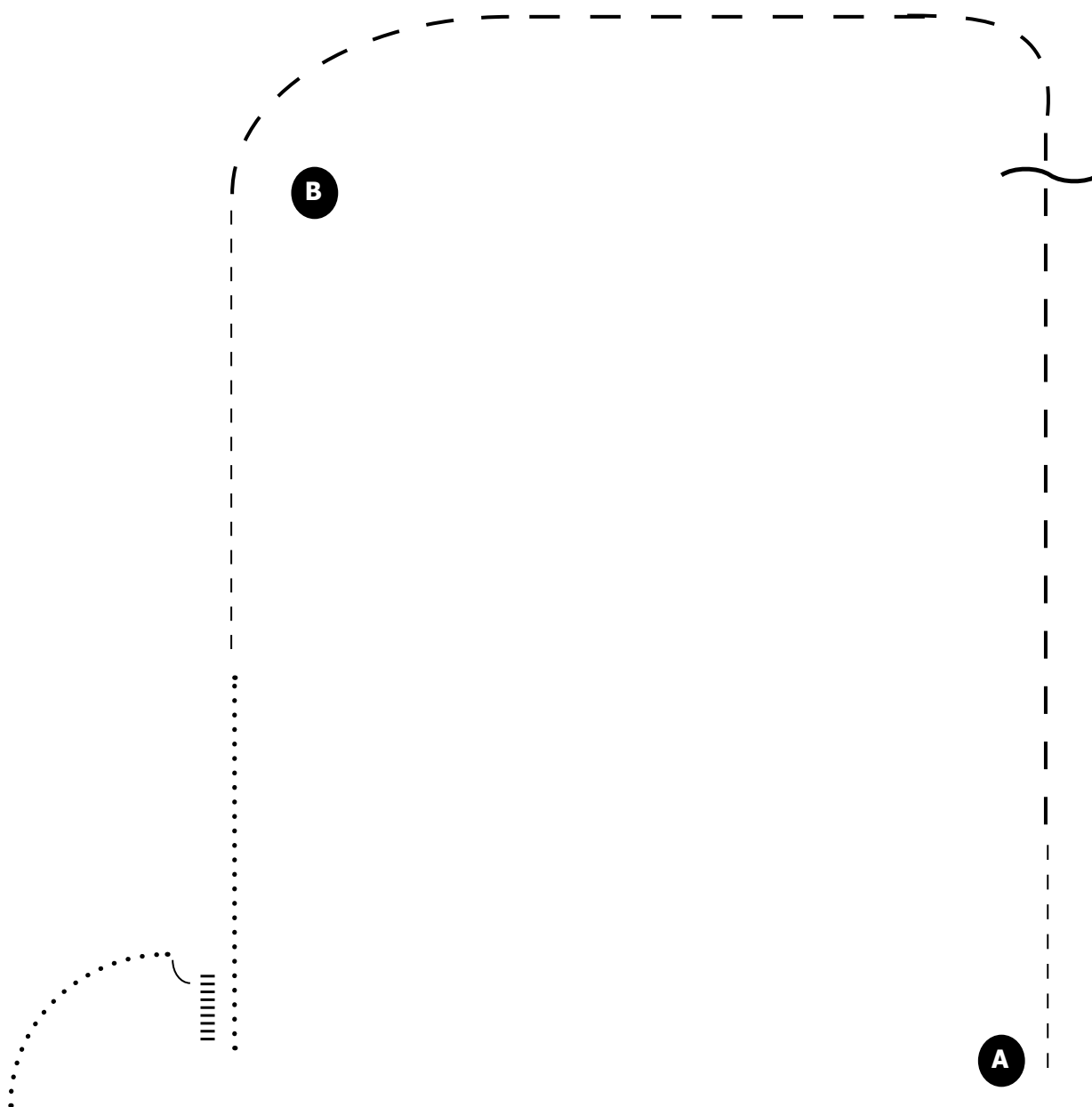

1. Sitting trot.
2. Posting trot, starting on the left diagonal, switching before the turn.
3. Sitting trot.
4. Walk.
5. Stop, back, execute $\frac{1}{4}$ turn right on the forehand.
6. Walk to exit.

Walk
Sitting Trot	-----
Posting Trot	— —
Canter	————
Back	

Hunt Seat Equitation

all classes except Walk/Trot

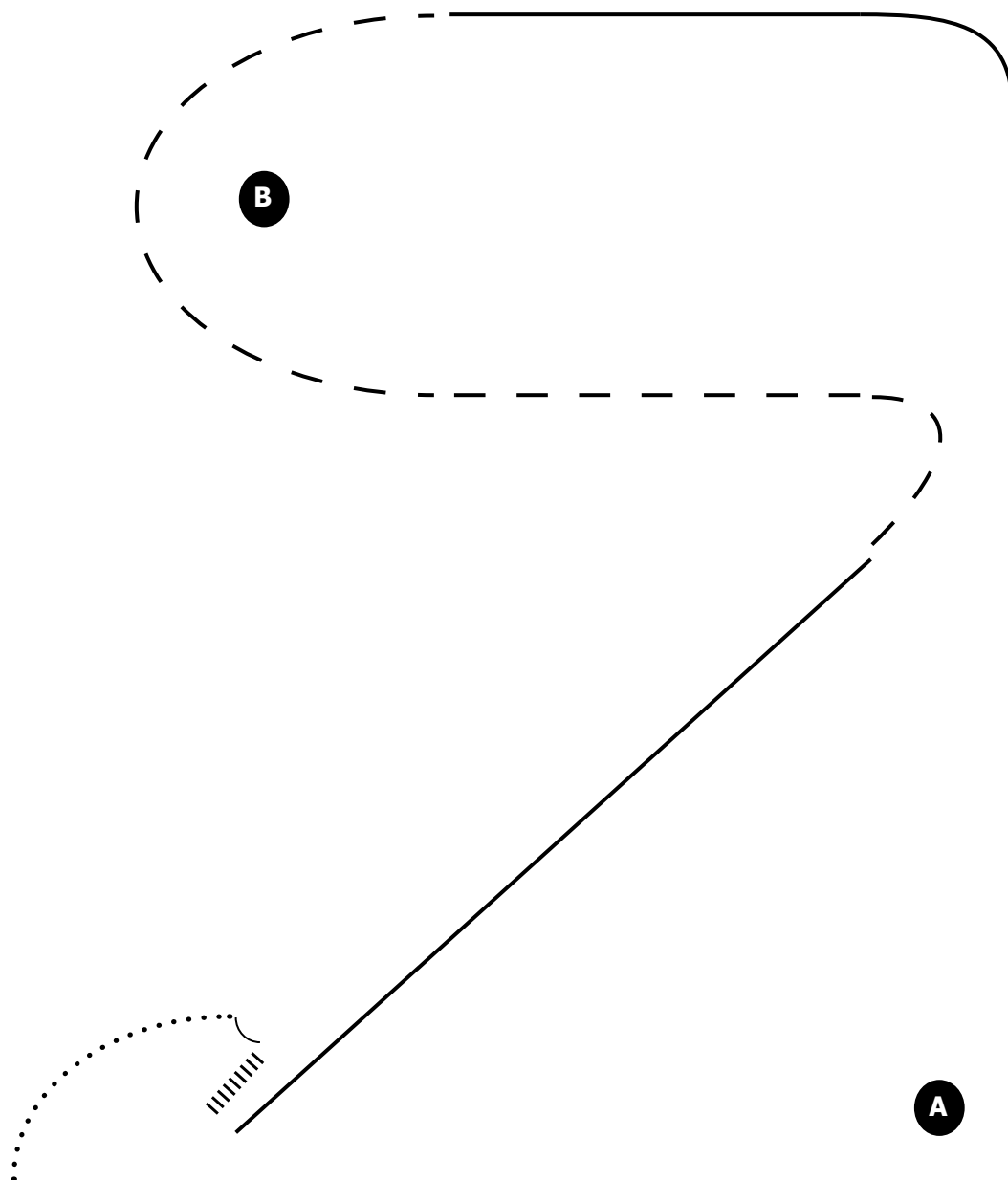

Walk

Sitting Trot - - - -

Posting Trot - -

Canter _____

Back |||||

1. Sitting trot
2. Canter, left lead.
3. Trot
4. Canter, right lead.
5. Stop, back, execute $\frac{1}{4}$ turn right on the forehand.
6. Walk to exit.

Ranch Riding

All Classes except Walk/Trot

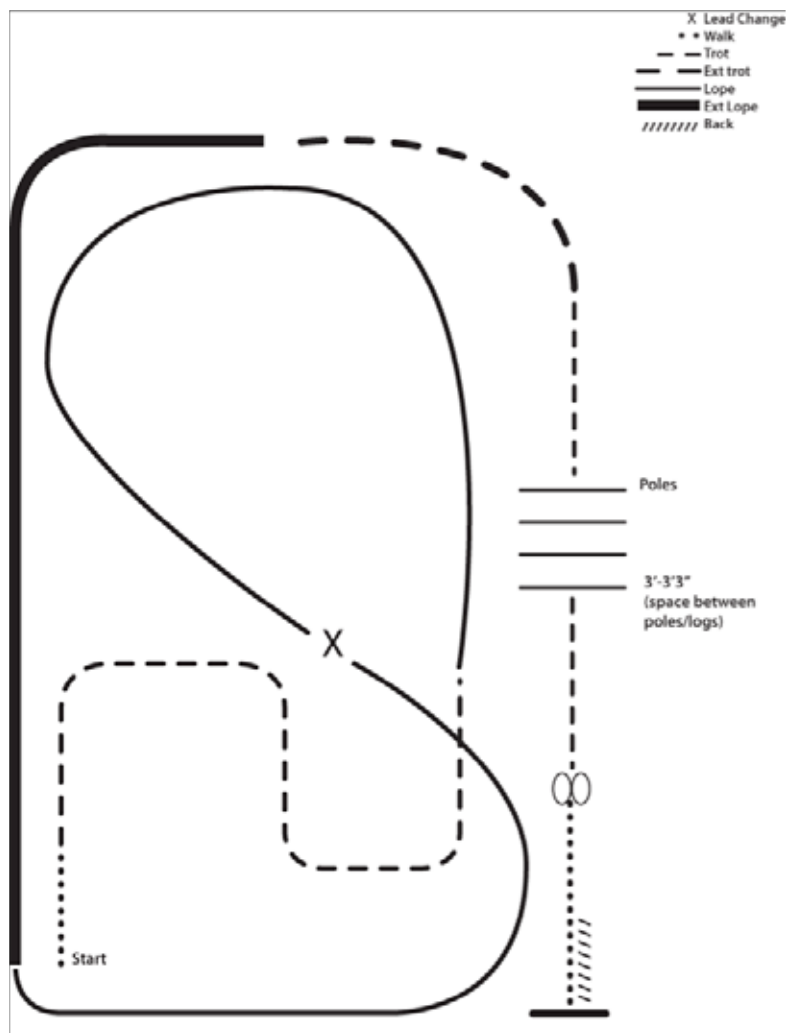

Pattern #4

1. Walk
2. Trot serpentine
3. Lope left lead around the end of the arena and then diagonally across the arena
4. Change leads (simple or flying)
5. Lope on the right lead around end of the arena
6. Extend lope on the straight away and around corner to the center of the arena
7. Extend trot around corner of the arena
8. Collect to a trot
9. Jog over poles
10. Stop, do 360° turn each direction (either direction 1st) (L-R or R-L)
11. Walk, stop and back

Ranch Riding

Walk Trot

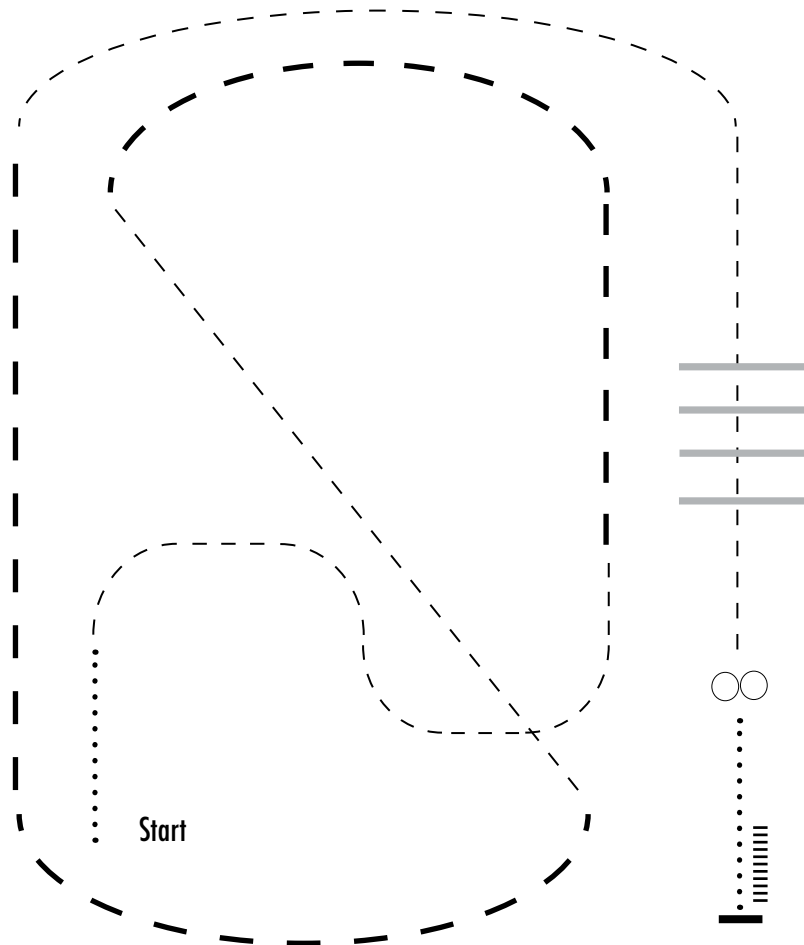

1. Walk
2. Trot
3. Extended trot
4. Trot
5. Extended trot
6. Trot
7. Trot over logs
8. Stop
9. 360° turn each direction (either way 1st)
10. Walk
11. Stop, back

Reining

All Classes

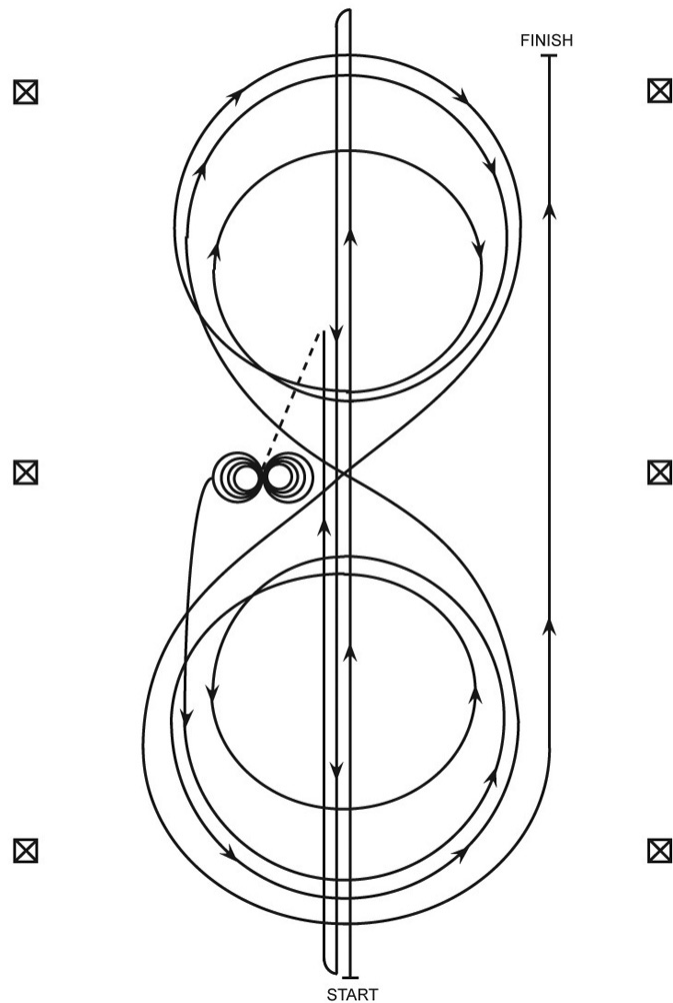

NRHA #1

1. Run at speed to the far end of the arena past the end marker and do a left rollback—no hesitation.
2. Run to the opposite end of the arena past the end marker and do a right rollback—no hesitation.
3. Run past the center marker and do a sliding stop. Back up to center of the arena or at least ten feet (three meters). Hesitate.
4. Complete four spins to the right. Hesitate.
5. Complete four and one-quarter spins to the left so that horse is facing left wall or fence. Hesitate.
6. Beginning on the left lead, complete three circles to the left: the first circle large and fast; the second circle small and slow; the third circle large and fast. Change leads at the center of the arena.
7. Complete three circles to the right: the first circle large and fast; the second circle small and slow; the third circle large and fast. Change leads at the center of the arena.
8. Begin a large circle to the left but do not close this circle. Run straight up the right side of the arena past the center marker and do a sliding stop at least twenty feet (six meters) from wall or fence. Hesitate to demonstrate the completion of the pattern.

Trail

all classes

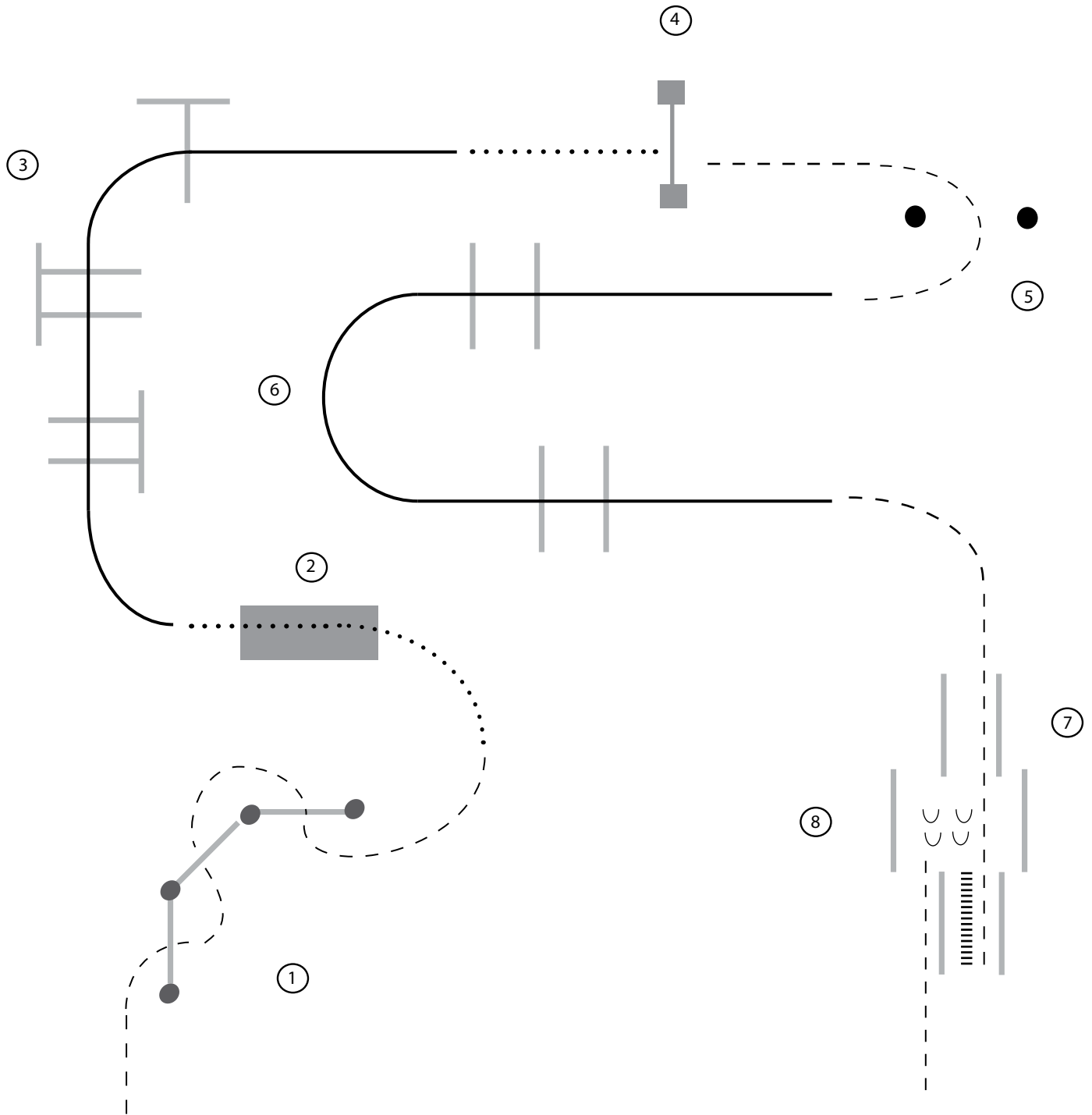

Instructions

1. Jog serpentine.
2. Walk over bridge.
3. Lope, right lead, over poles.
4. Walk to gate, work gate, right hand.
5. Jog through cones.
6. Lope, left lead, over poles.
7. Jog into chute.
8. Back to middle of chute, sidepass right. Jog to exit.

Walk
Jog	-----
Lope	—————
Back	
Sidepass	∩ ∩ ∩

Ranch Trail

all classes

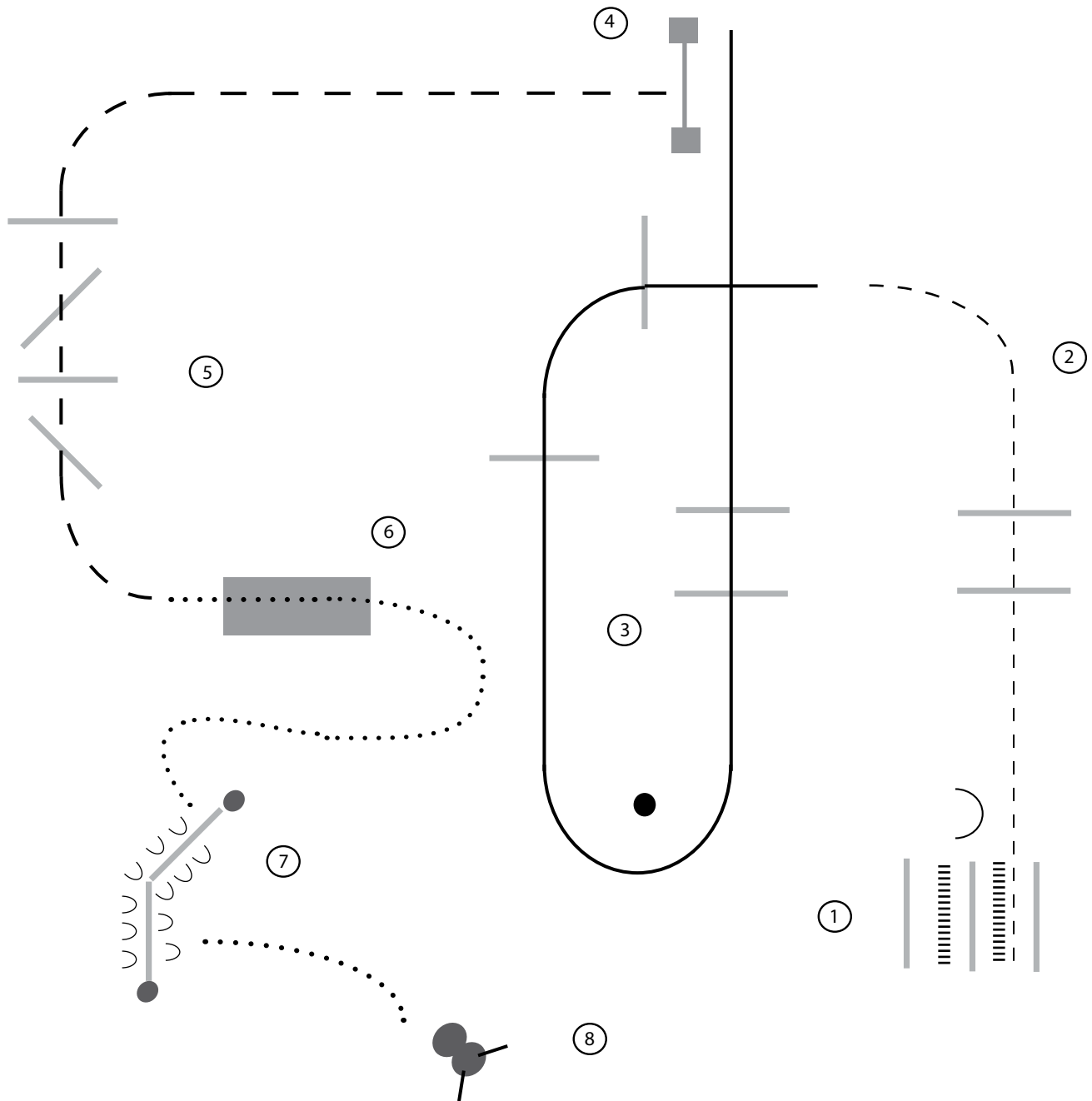

1. Back first chute, turn, back second chute
2. Trot poles
3. Lope, left lead, poles.
4. Work gate, left hand

5. Extended trot poles
6. Walk over bridge
7. Walk to logs, step front feet over, sidepass right
8. Walk to steer, throw loop, exit arena

Walk
Trot	-----
Ext. Trot	—— —
Lope	————
Back	
Sidepass	∩ ∩ ∩

Ranch Ground Handling

all classes

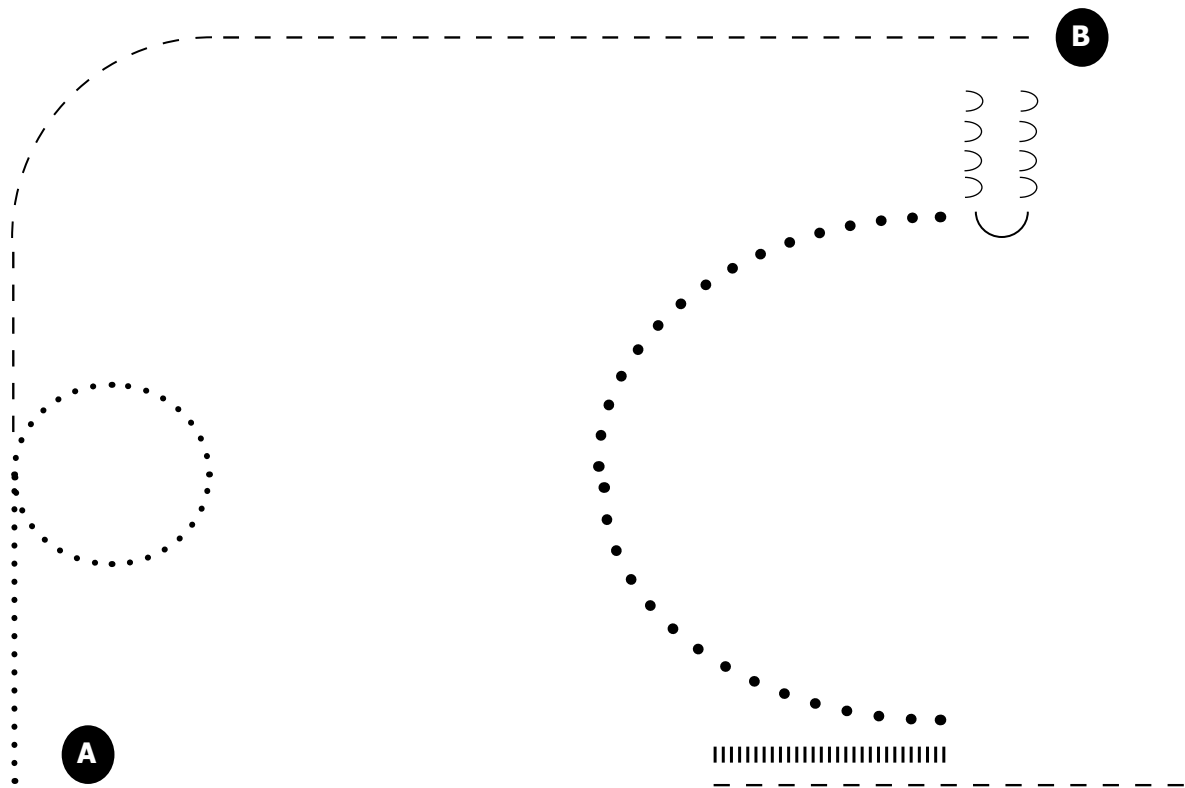

1. Start at A with horse on a long lead. Gather lead and walk forward
2. Walk small circle to the right.
3. Trot curve to B, stop.
4. Seniors(class 37) -Sidepass several strides
Juniors(class 36)-do not sidepass
5. Execute $\frac{1}{2}$ turn on the haunches
6. Extended walk half circle
7. Stop, back at least two horse lengths
8. Demonstrate lowering horse's head
9. Trot to exit