

# Pattern

---

# Book

Tulsa State Fair  
Junior and Open Horse Show

2025  
Tulsa, OK

# Showmanship

Class 35 • 10 & Under

Class 36 • 3rd-7th grade

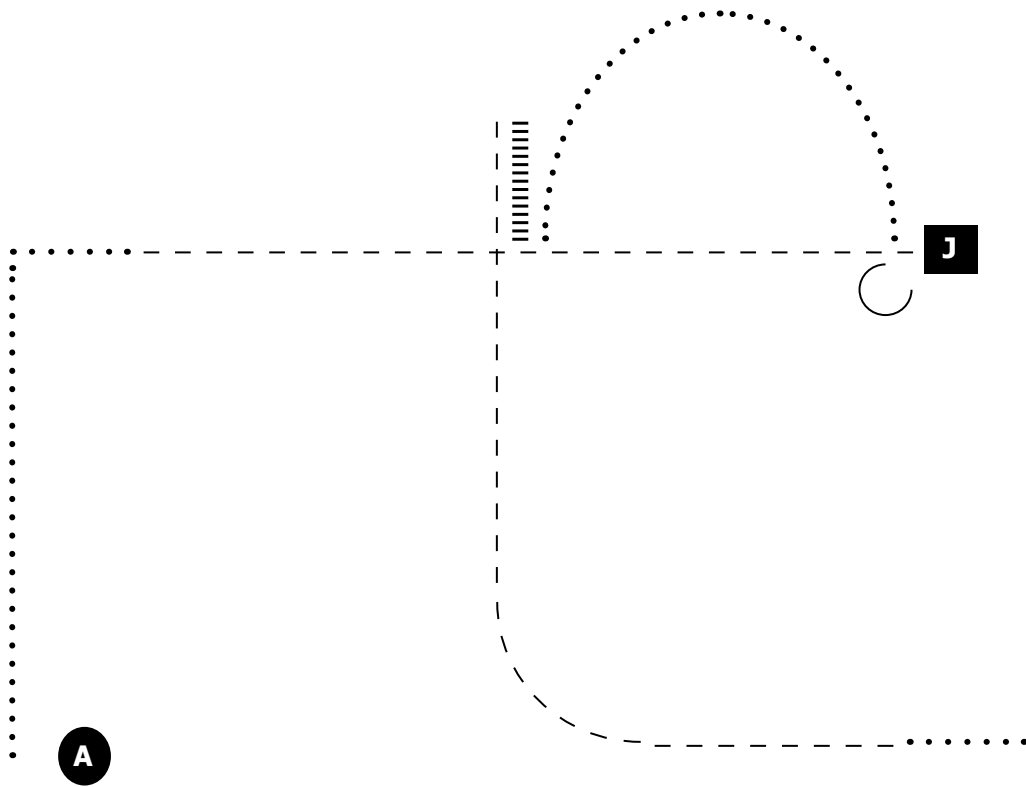

1. Walk corner
2. Trot to Judge
3. Stop, set up
4. Inspection
5. When dismissed, execute  $\frac{3}{4}$  turn
- 6 Walk
7. Stop, back one horse length
8. Trot
9. Walk to exit

Walk	.....
Trot	-----
Back	
Judge	<b>J</b>

# Showmanship

Class 37 • 8th-12th grade

Class 38 • Open

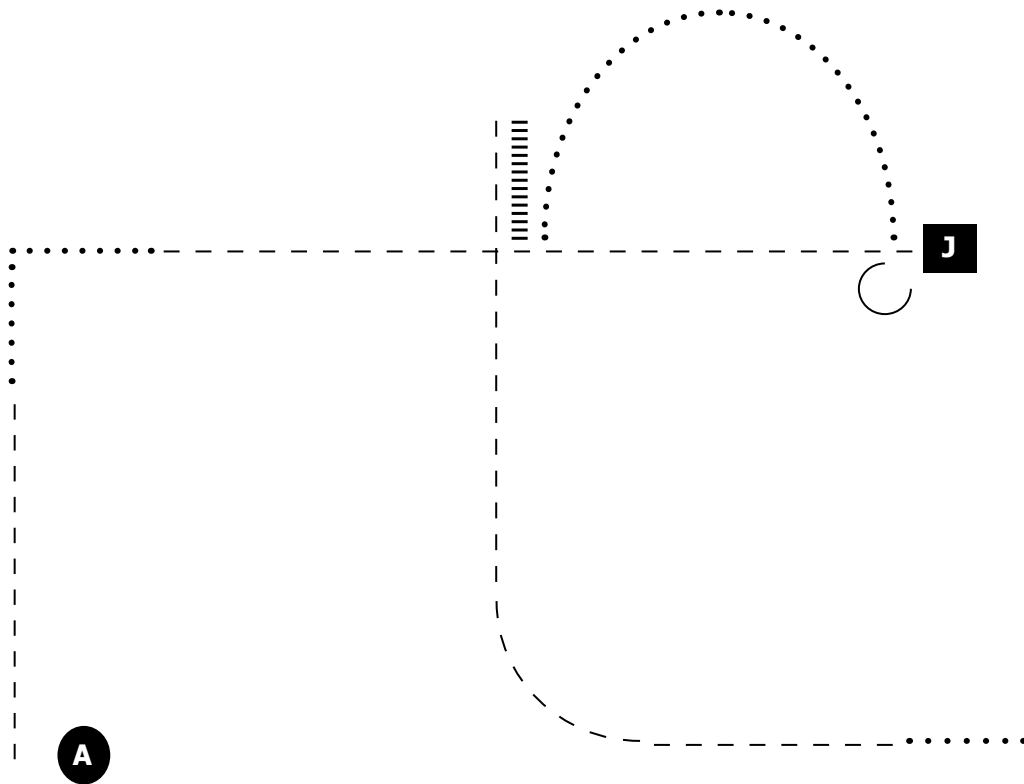

1. Trot
2. Walk corner
3. Trot to Judge
4. Stop, set up
5. Inspection
6. When dismissed, execute  $\frac{3}{4}$  turn
7. Walk
8. Stop, back one horse length
9. Trot
10. Walk to exit

Walk	.....
Trot	-----
Back	
Judge	<b>J</b>



# Western Horsemanship

Class 10 • 3rd-7th grade

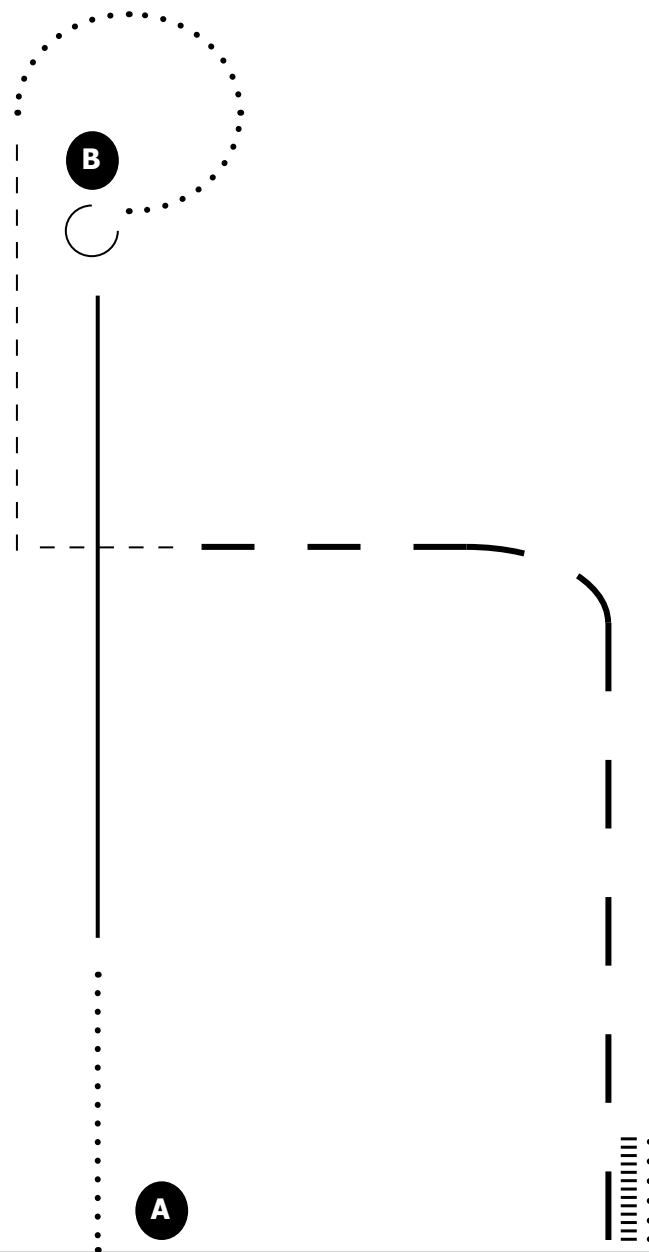

1. Walk several strides
2. Lope, left lead
3. Stop at B, execute  $\frac{3}{4}$  turn left on the haunches
4. Walk around B
5. Jog square corner
6. Extended jog until even with A
7. Stop, back one horse length
8. Walk to exit

Walk	.....
Jog	-----
Ext. Jog	-----
Lope	—————
Back	

# Western Horsemanship

Class 11 • 8th-12th grade

Class 12 • Open

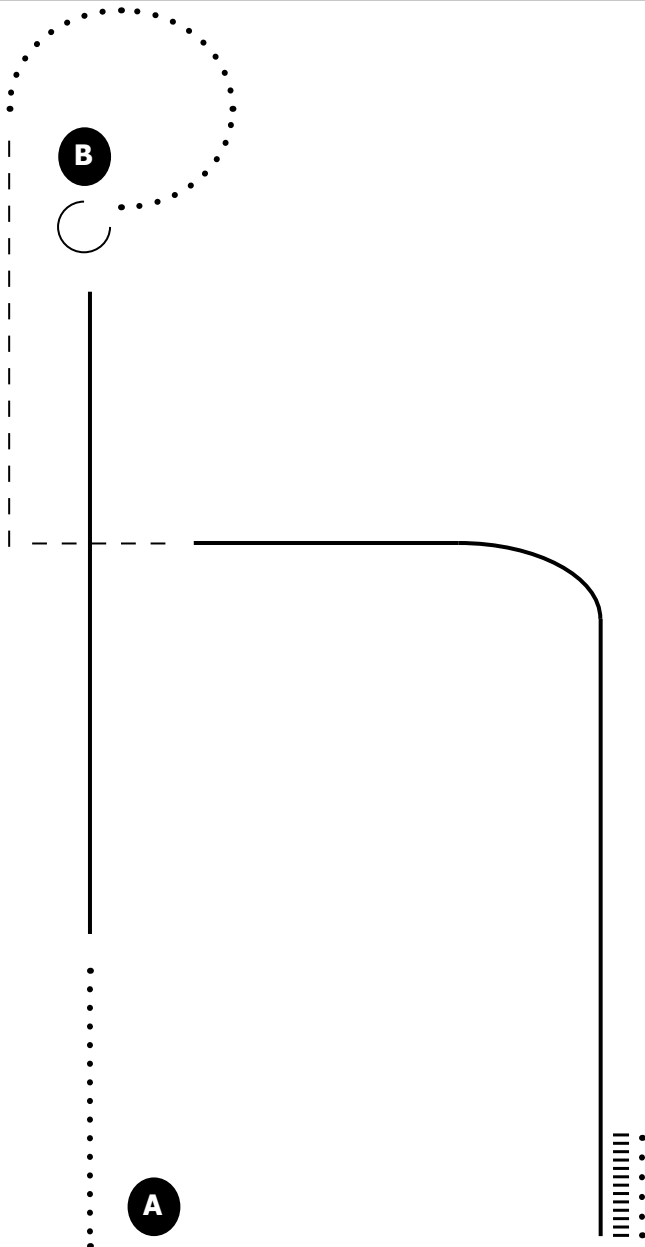

1. Walk several strides
2. Lope, left lead
3. Stop at B, execute  $\frac{3}{4}$  turn left on the haunches
4. Walk around B
5. Jog square corner
6. Lope, right lead, until even with A
7. Stop, back one horse length
8. Walk to exit

Walk	•••••
Jog	- - - -
Ext. Jog	- -
Lope	—
Back	

# Hunt Seat Equitation

Class 47 • 10 & Under

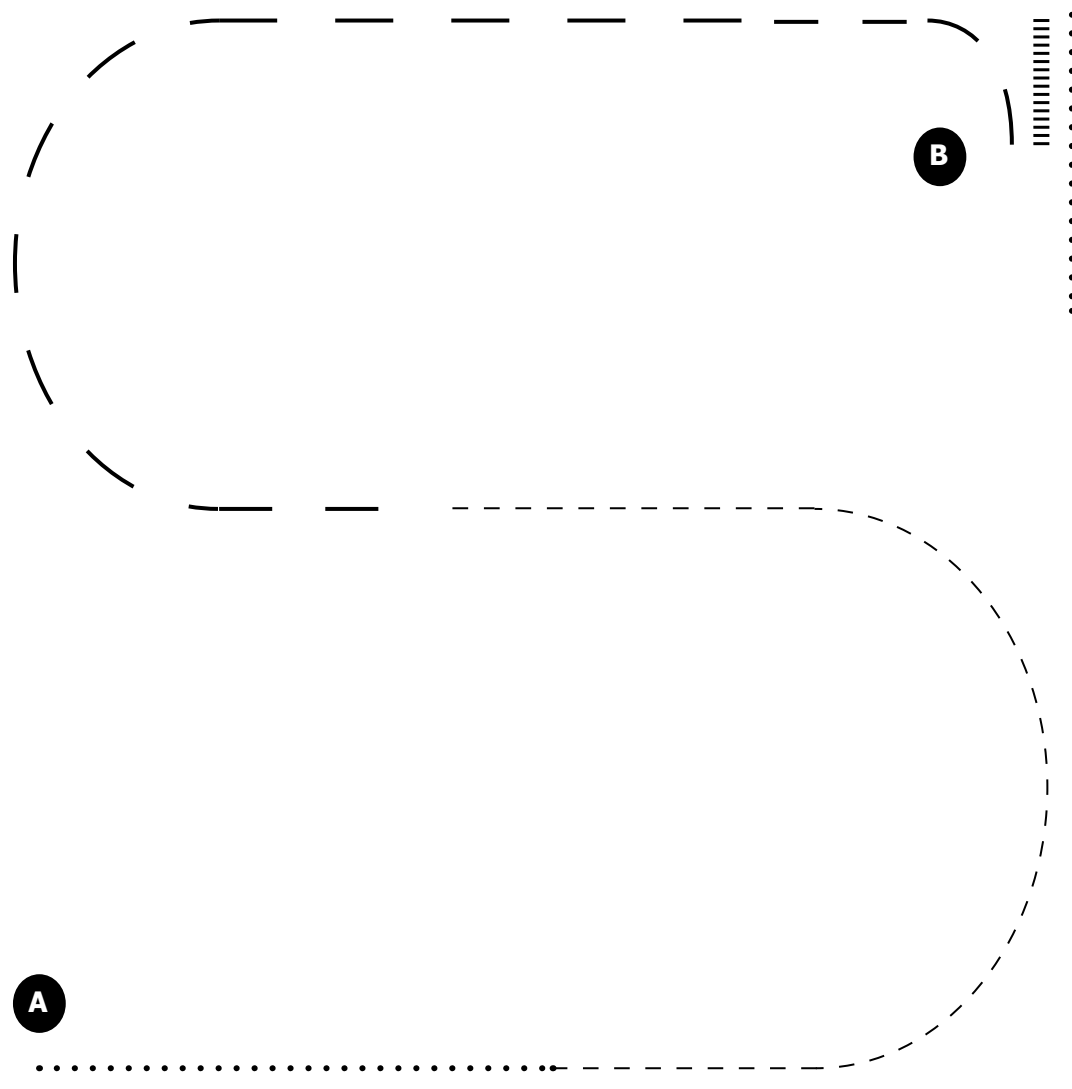

1. Walk
2. Sitting trot
3. Trot around B
4. Stop, back one horse length
5. Walk several strides
6. Trot to exit, either diagonal

Walk	.....
Sitting Trot	- - - -
Posting Trot	- - - -
Canter	————
Back	

# Hunt Seat Equitation

Class 48 • 3rd-7th grade

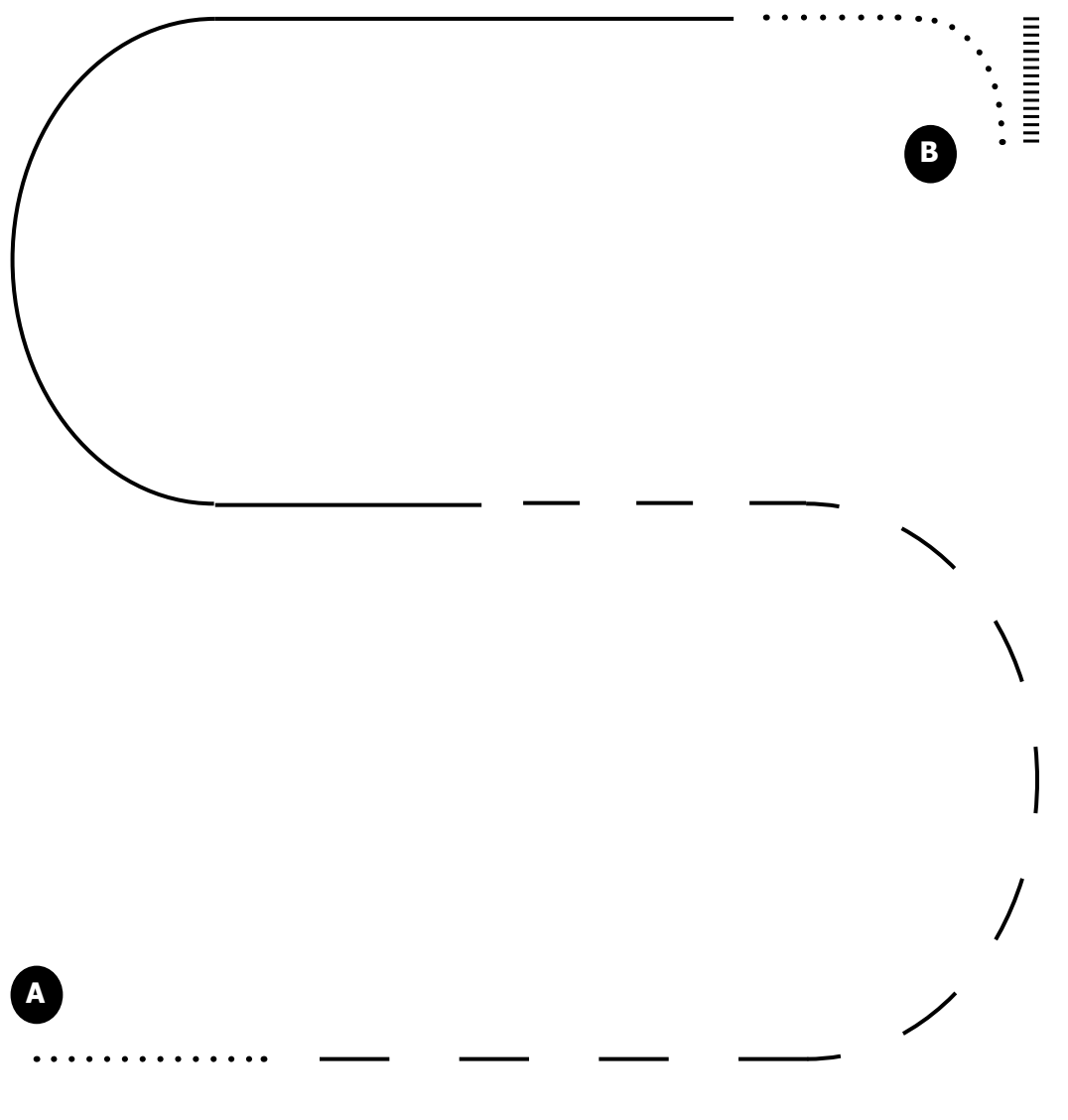

1. Walk several strides
2. Trot
3. Canter, right lead
4. Walk to B
5. Stop, back one horse length
6. Sitting trot
7. Trot to exit

Walk .....

Sitting Trot - - - -

Posting Trot — — —

Canter —————

Back |||||

# Hunt Seat Equitation

Class 49 • 8th-12th grade

Class 50 • Open

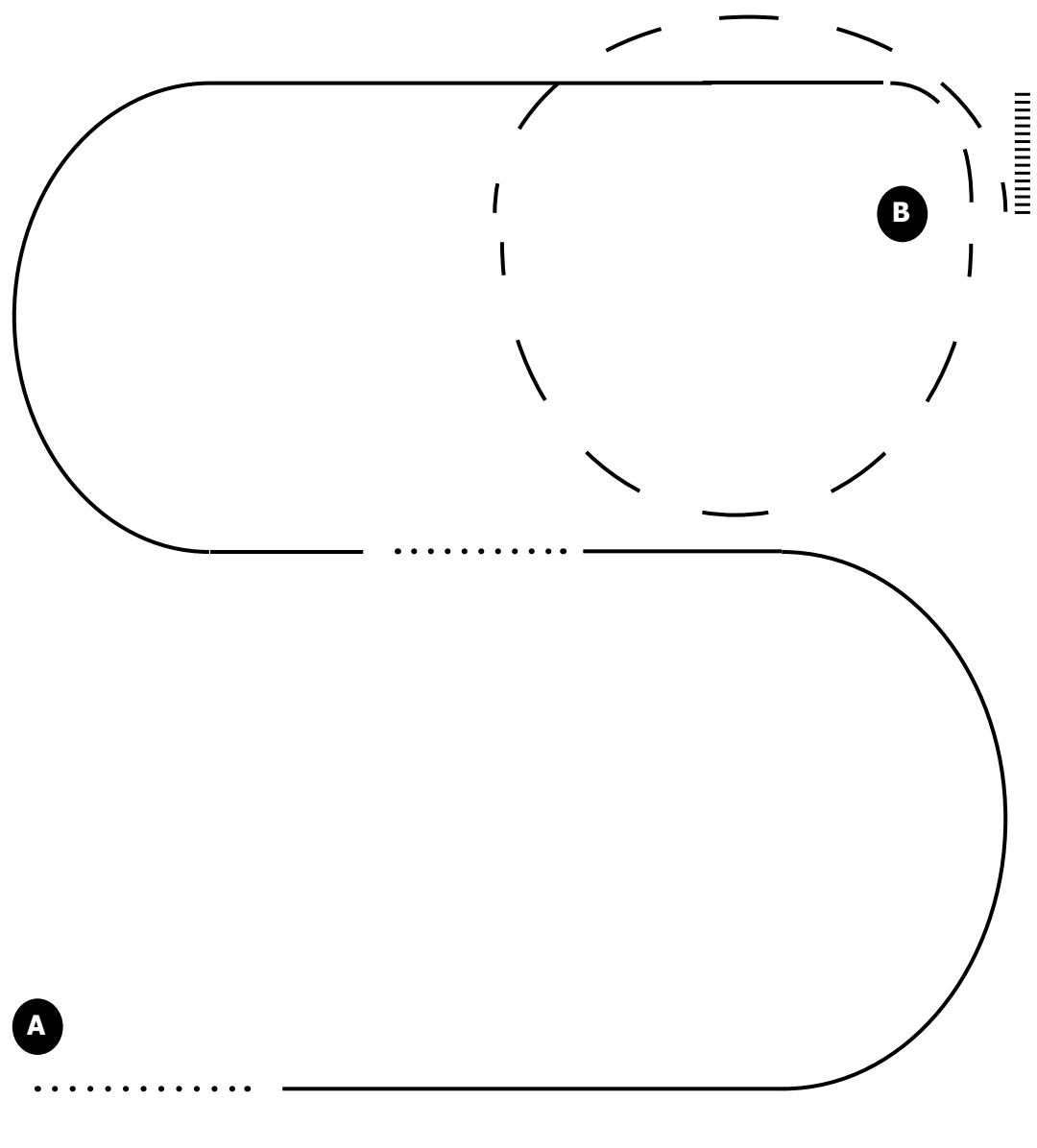

1. Walk several strides
2. Canter, left lead
3. Walk several strides
4. Canter, right lead
5. Trot circle around B
6. Stop, back one horse length
7. Sitting trot
8. Trot to exit

Walk	.....
Sitting Trot	- - - -
Posting Trot	- - - -
Canter	————
Back	

# Ranch Riding

Class 19, 20, 21

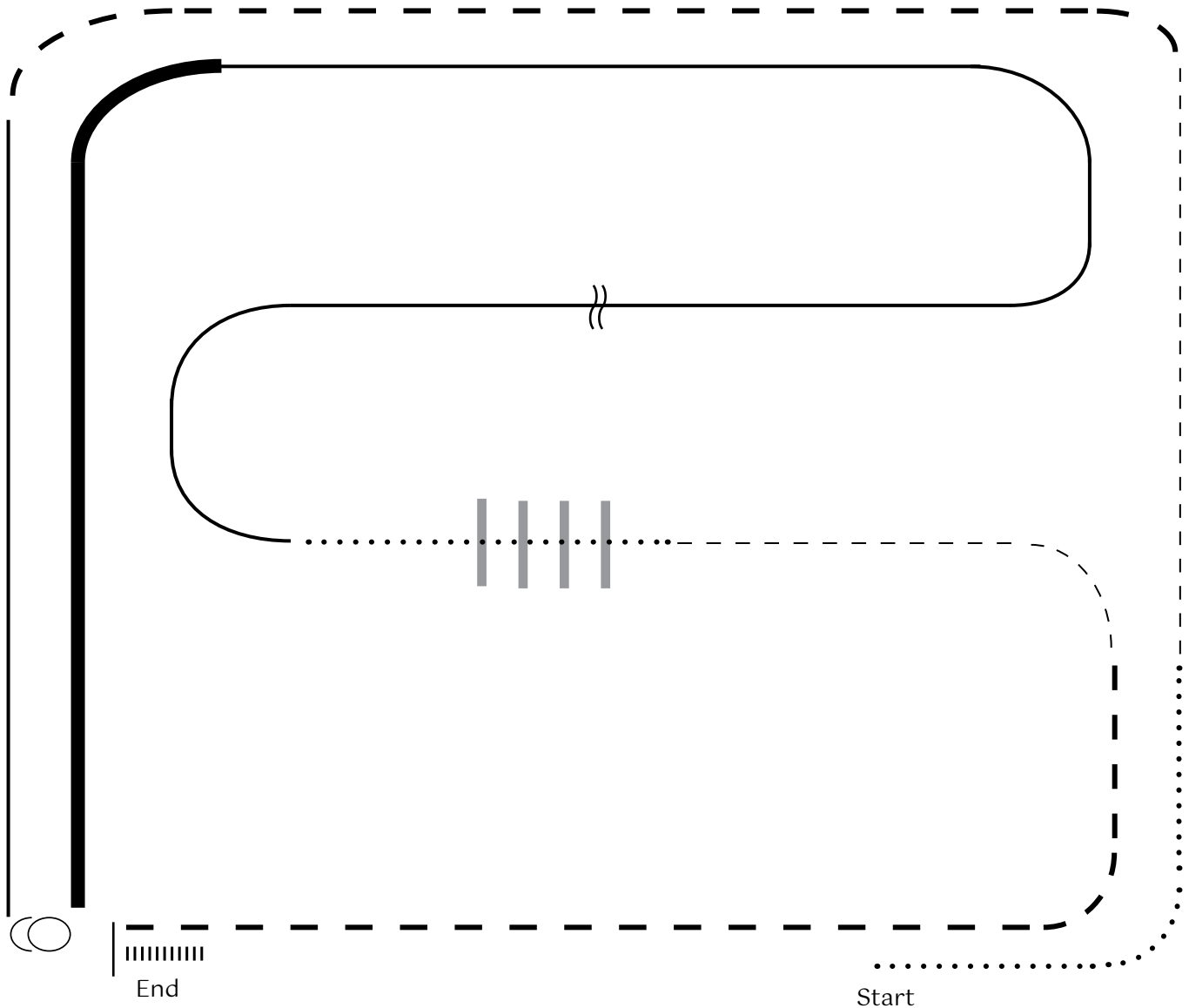

## AQHA Pattern 2

1. Walk
2. Trot
3. Extended trot
4. Lope, left lead
5. Stop, 1½ turn right
6. Extended lope, right lead
7. Collect to working lope
8. Change leads, simple or flying

9. Walk
10. Walk over logs
11. Trot
12. Extended trot
13. Stop and back

Walk	.....
Trot	- - - - -
Ext. Trot	- - - - -
Lope	—————
Ext. Lope	—————
Back	
Lead Change	))

# Ranch Riding

Class 18

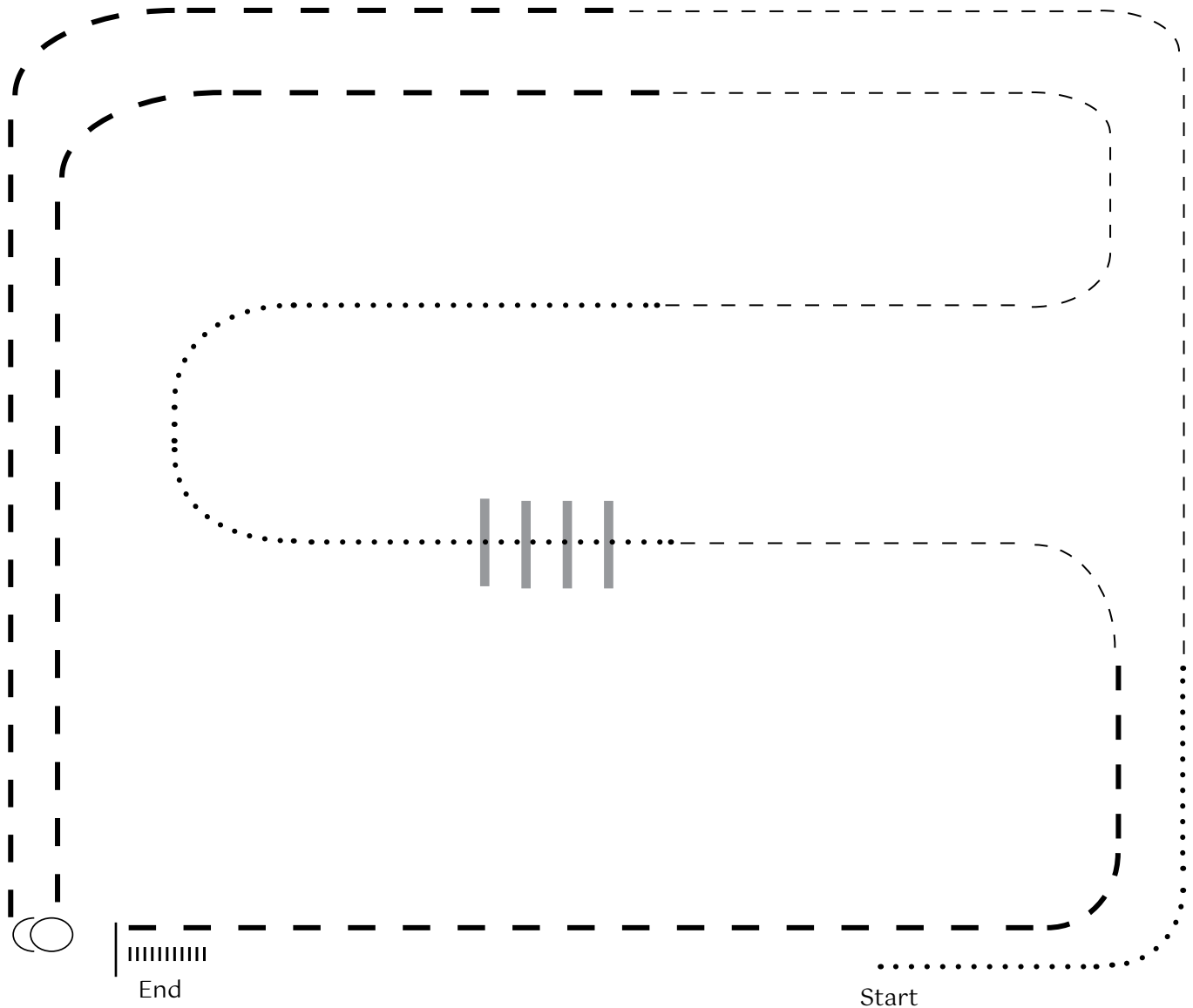

1. Walk
2. Trot
3. Extended trot
4. Stop, 1½ turn right
5. Extended trot
6. Trot
7. Walk
8. Walk over logs
9. Trot
10. Extended trot
11. Stop and back

Walk	.....
Trot	- - - - -
Ext. Trot	- - - - -
Back	

# Reining

Class 7, 8

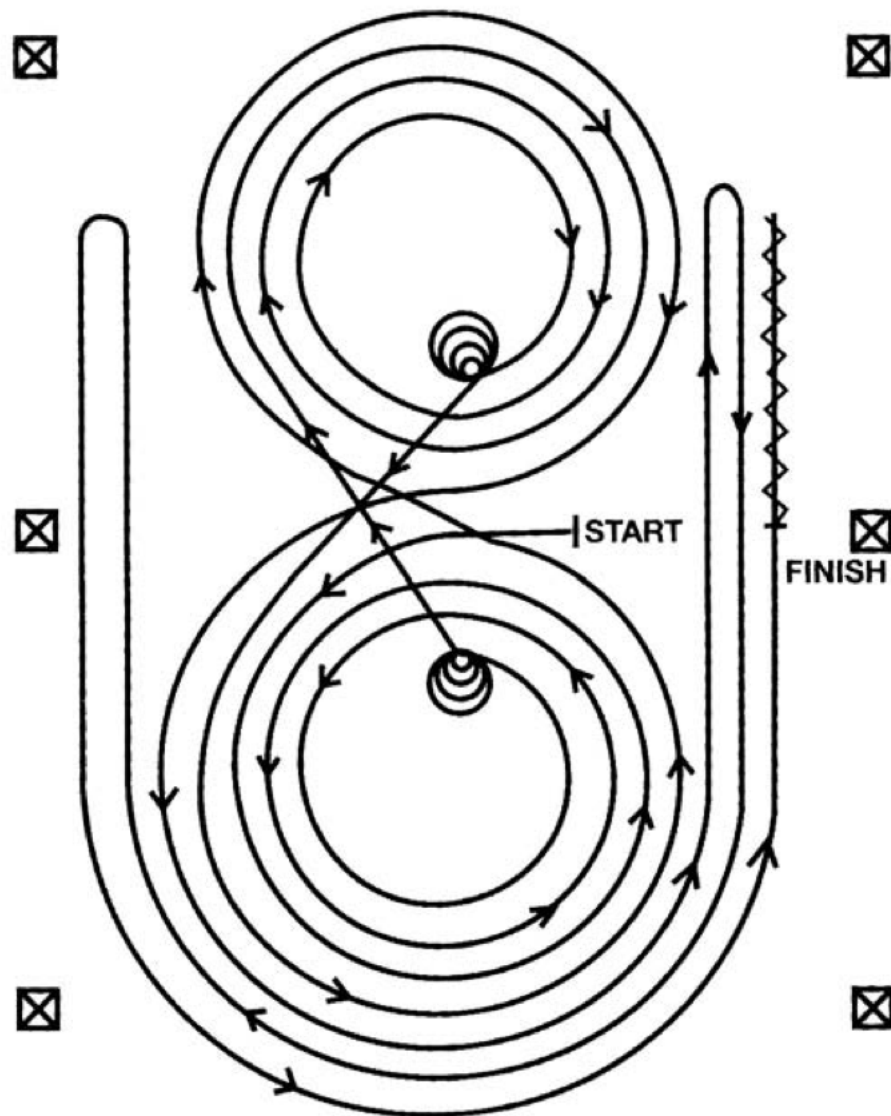

## NRHA 5

Horses may walk or trot to the center of arena.

Horses must walk or stop prior to starting pattern.

Beginning at the center of the arena facing the left wall or fence.

1. Beginning on the left lead, complete three circles to the left: the first two circles large and fast; the third circle small and slow. Stop at the center of the arena. Hesitate.
2. Complete four spins to the left. Hesitate.
3. Beginning on the right lead, complete three circles to the right: the first two circles large and fast; the third circle small and slow. Stop at the center of the arena. Hesitate.
4. Complete four spins to the right. Hesitate.
5. Beginning on the left lead, run a large fast circle to the left, change leads at the center of the arena, run a large fast circle to the right, and change leads at the center of the arena.
6. Continue around previous circle to the left but do not close this circle. Run up the right side of the arena past the center marker and do a right roll back at least twenty feet (six meters) from the wall or fence – no hesitation.
7. Continue around previous circle but do not close this circle. Run up the left side of the arena past the center marker and do a left rollback at least twenty feet (six meters) from the wall or fence – no hesitation.
8. Continue back around previous circle but do not close this circle. Run up the right side of the arena past the center marker and do a sliding stop at least twenty feet (six meters) from the wall or fence. Back up at least ten feet (three meters). Hesitate to demonstrate completion of the pattern.

# Trail

Class 1, 2, 3

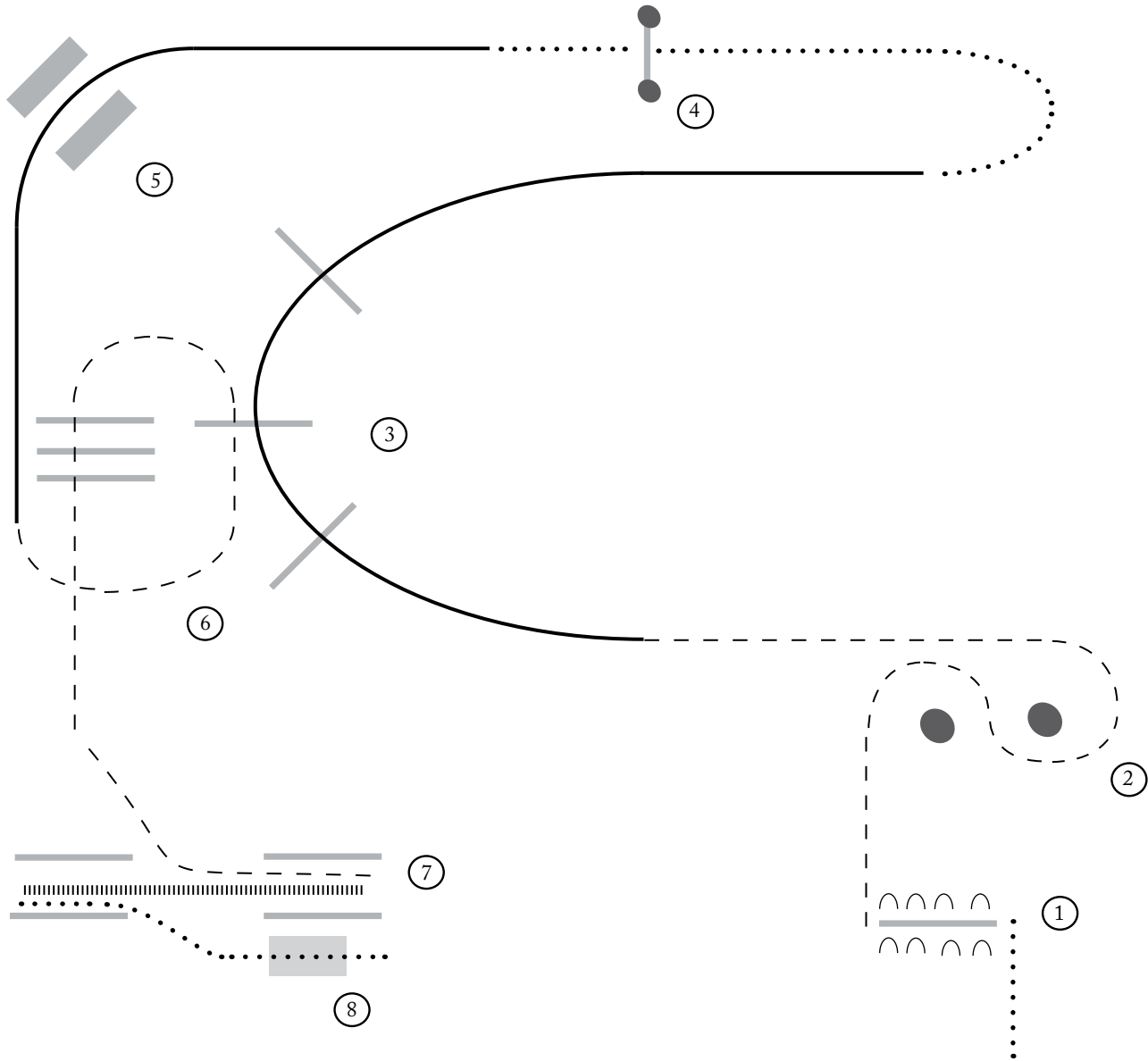

1. Walk to pole, stop, sidepass left over pole
2. Jog serpentine
3. Lope, right lead, over poles
4. Walk to gate, work gate, right hand, walk away from gate
5. Lope, left lead, through chute
6. Jog over poles and into chute
7. Stop, back
8. Walk out of chute and over bridge

Walk	.....
Jog	- - - -
Lope	—————
Back	
Sidepass	∩ ∩ ∩

# Ranch Trail

Class 4, 5, 6

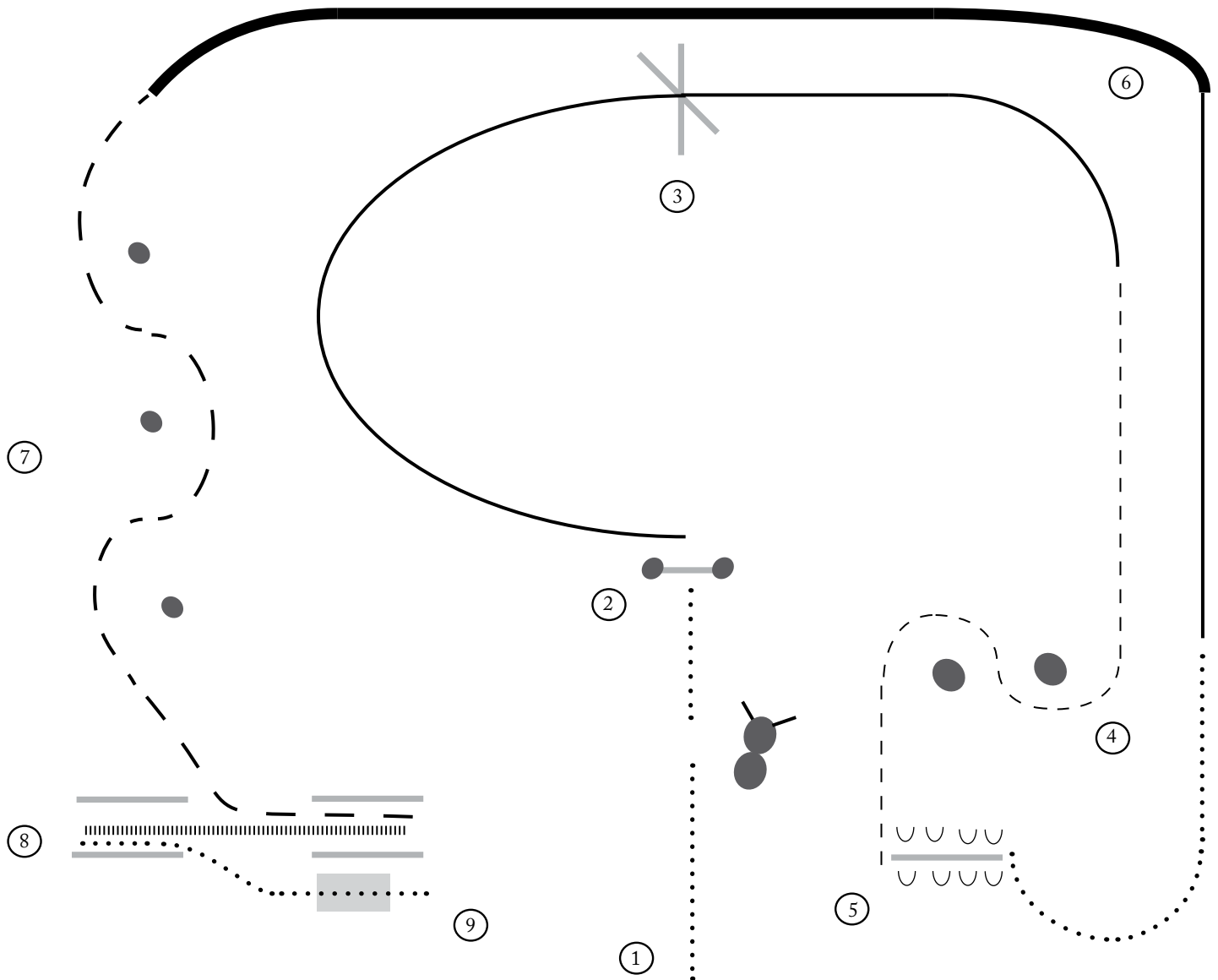

1. Walk in with rope in hand, walk to dummy, stop, rope dummy, drop rope after one throw
2. Walk to gate, work gate, left hand
3. Lope, right lead, over jump
4. Jog around obstacles
5. Stop, sidepass left
6. Walk, lope, left lead, extend lope
7. Extended trot serpentine and into chute
8. Stop, back
9. Walk out of chute and over bridge to exit

Walk	.....
Trot	-----
Lope	=====
Extended lope	=====
Back	
Sidepass	∪ ∪ ∪

# Ranch Ground Handling

Class 39 • 10 & Under

Class 40 • 3rd-7th grade

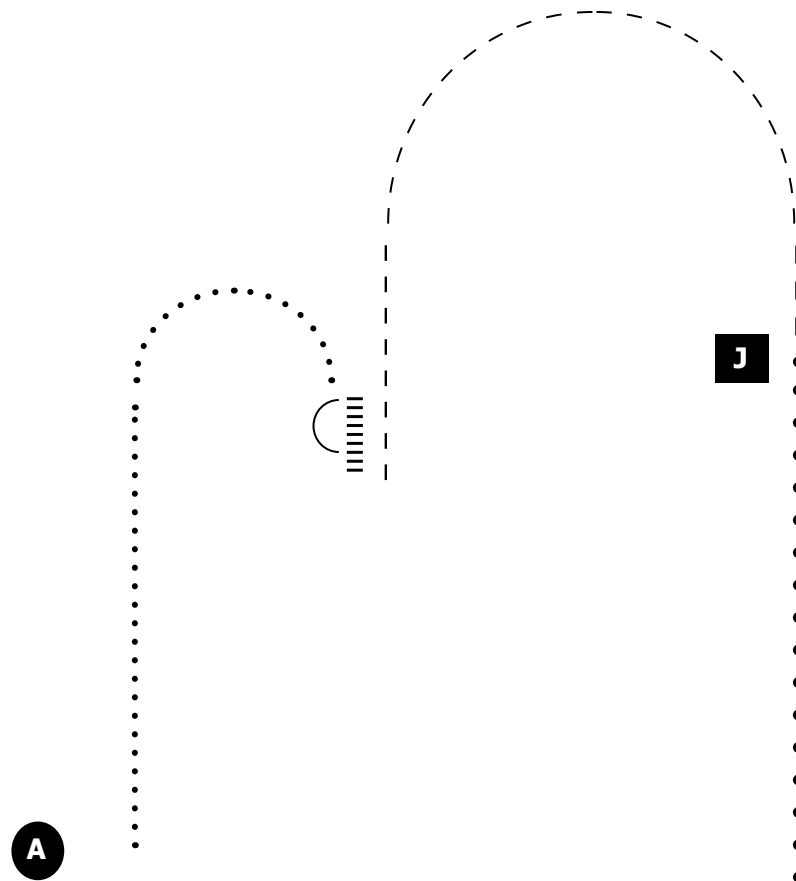

1. Walk
2. Stop, execute  $\frac{1}{2}$  turn on the haunches
3. Back horse several steps while handler remains stationary
4. Trot half circle and stop when Judge is on right side of horse
5. Lower the horses head briefly then present horse to Judge
6. Answer question from Judge
7. Extended walk to exit

Walk	.....
Ext. Walk	• • •
Trot	- - - -
Back	
Judge	<b>J</b>

# Ranch Ground Handling

Class 41 • 8th-12th grade

Class 42 • Open

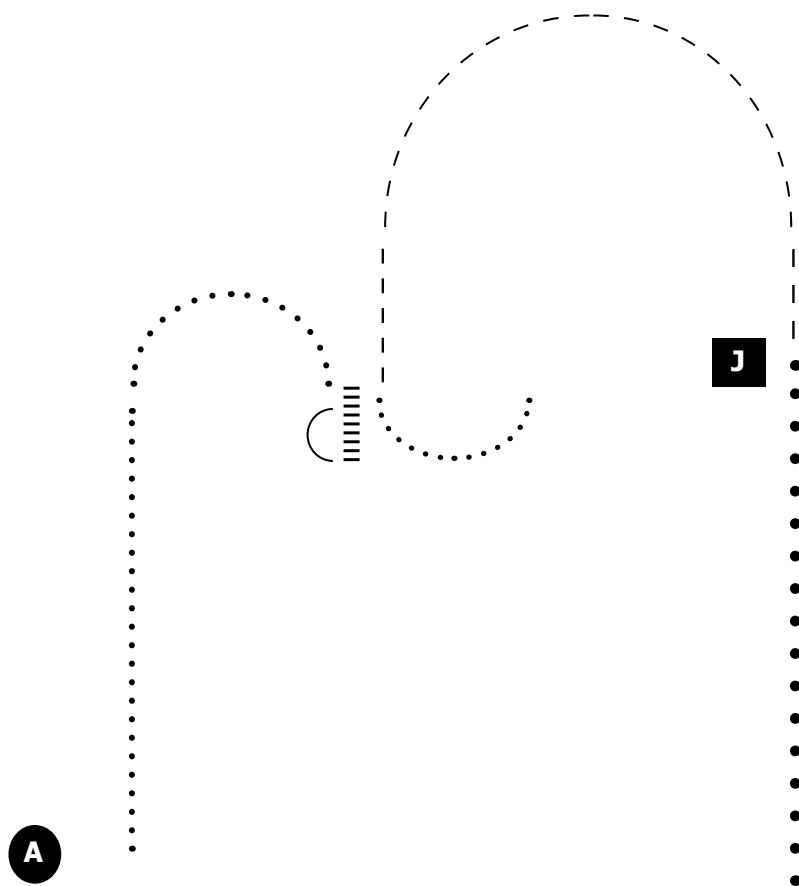

1. Walk
2. Stop, execute  $\frac{1}{2}$  turn on the haunches
3. Back horse several steps while handler remains stationary
4. Ground tie - drop lead, walk in front of horse to off side then back to near side - gather lead.
5. Trot half circle and stop when Judge is on right side of horse
6. Lower the horses head briefly then present horse to Judge
7. Answer question from Judge
8. Extended walk to exit

Walk	.....
Ext. Walk	• • •
Trot	- - - -
Back	
Judge	<b>J</b>